



Operating Instructions



**IMPORTANT!**

**Read contents carefully prior to operation.**





This card to be stored with the Vision Plus operator guide in a protected place on the vehicle within access of the operator. This information must be used in conjunction with the Vision Plus operator's guide. Read operator guide before using this system.



### SYSTEM CONFIGURATION

Serial Number: \_\_\_\_\_

Model Number: \_\_\_\_\_

Date: \_\_\_\_\_

Rev: \_\_\_\_\_ Init: \_\_\_\_\_

### SYSTEM COVERAGE AREAS

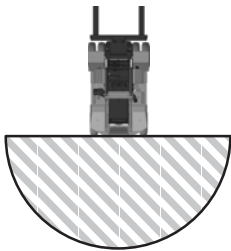

**A**

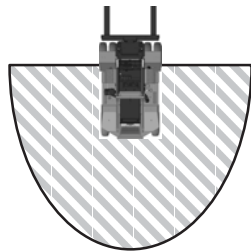

**B**

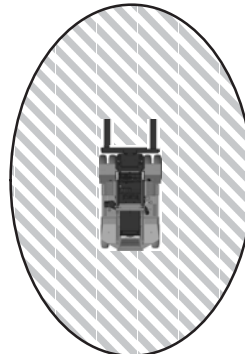

**C**

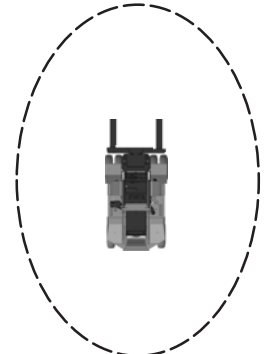

**D**

### COVERAGE AREA RANGE (approximate)

LOW SPEEDS 25 FT

MEDIUM SPEEDS 35 FT

HIGH SPEEDS 45 FT

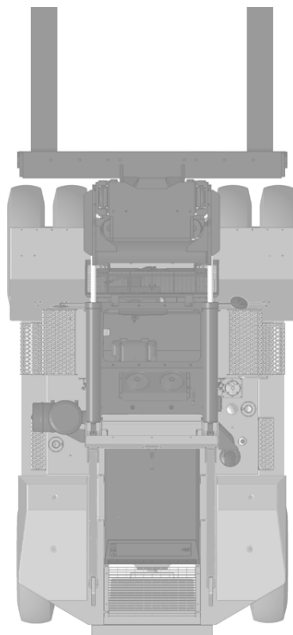

### CAMERA S/N

0: \_\_\_\_\_

1: \_\_\_\_\_

2: \_\_\_\_\_

3: \_\_\_\_\_

4: \_\_\_\_\_

5: \_\_\_\_\_

6: \_\_\_\_\_

7: \_\_\_\_\_

## An explanation of the alerts issued to the operator by the Vision Plus system.

Vision Plus alerts the operator when one or more pedestrians are located within the system coverage area. The type of coverage area chosen (A, B, C, or D) along with the mode of the transmission selected (FWD, N, REV) and the vehicle's speed will determine the portion of the system coverage area for which alerts are issued (illustrated below).

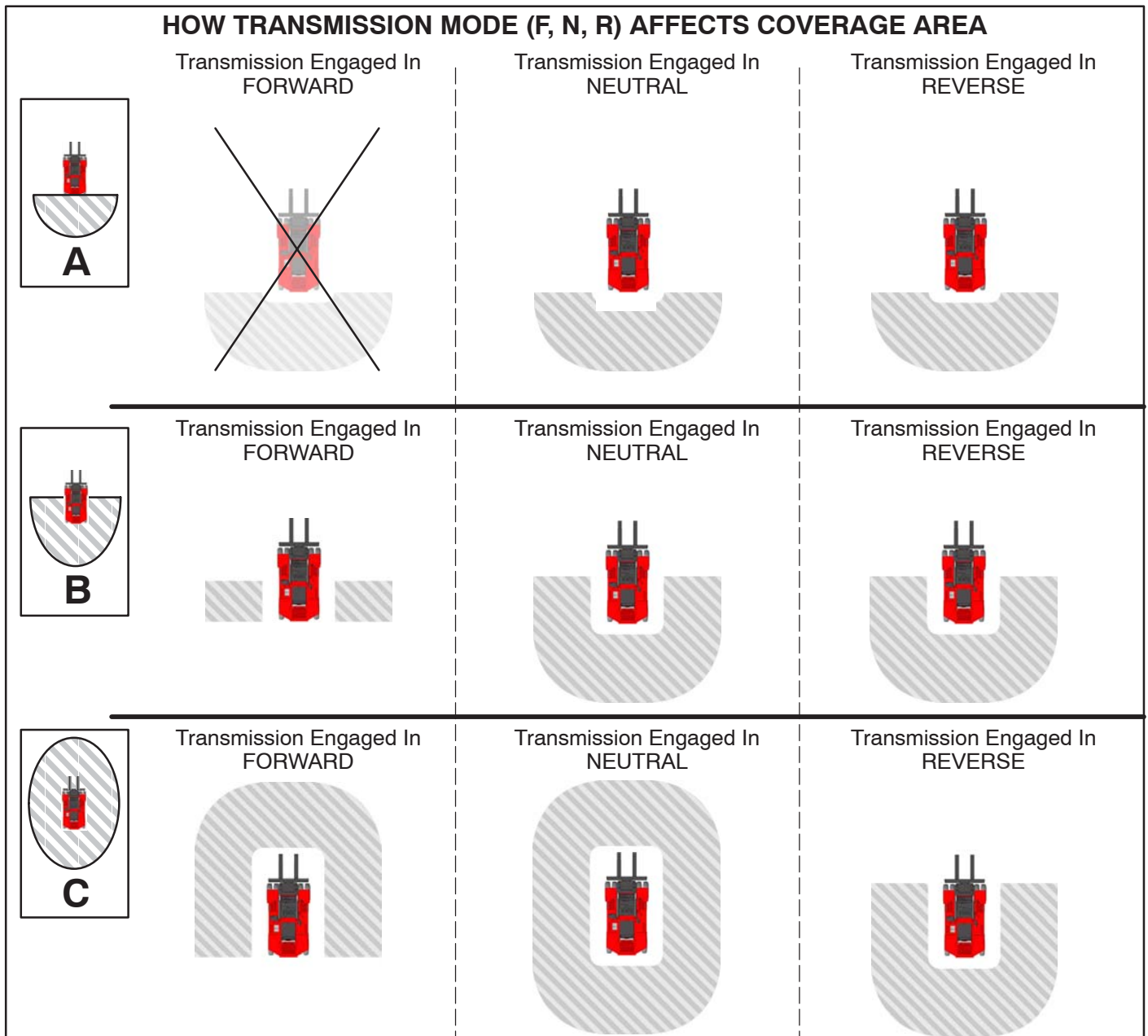
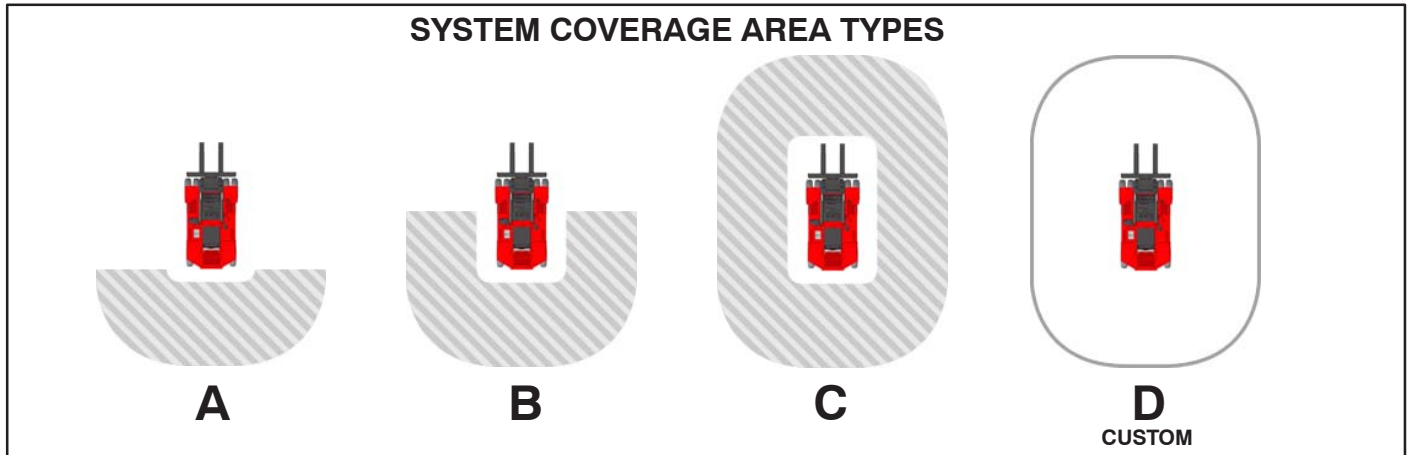

Vision Plus is designed to detect pedestrians within a 45ft maximum radius of the machine for all coverage area types (A, B, C, and D). However, the distance for which alerts are issued to the operator varies with the vehicle's speed (illustrated below). **Note:** All illustrations below depict coverage area Type C.

\* Refer to the **System Performance** section of the operator's guide, OG-182, for additional coverage area information.

### HOW VEHICLE SPEED AFFECTS COVERAGE AREA

LOW SPEEDS: ..... Approx. 25 FT

MEDIUM SPEEDS: ... Approx. 35 FT

HIGH SPEEDS: ..... Approx. 45 FT

Alert Issued: ✓  
Alert NOT Issued: ✗

**FORWARD @ LOW SPEEDS**  
(25FT COVERAGE AREA RADIUS)

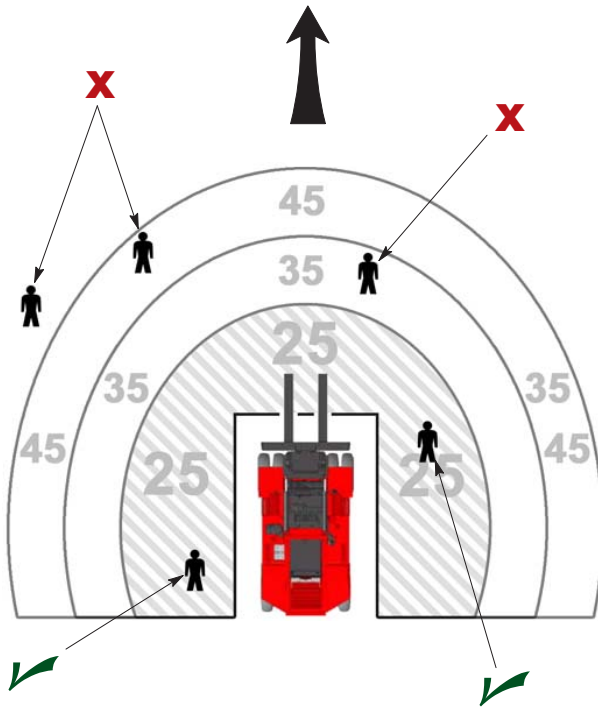

**FORWARD @ HIGH SPEEDS**  
(45FT COVERAGE AREA RADIUS)

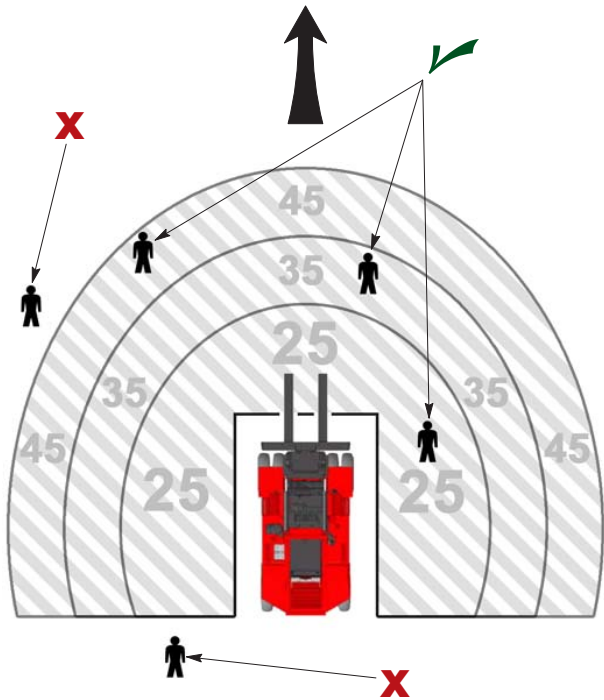

**REARWARD @ MEDIUM SPEEDS**  
(35FT COVERAGE AREA RADIUS)

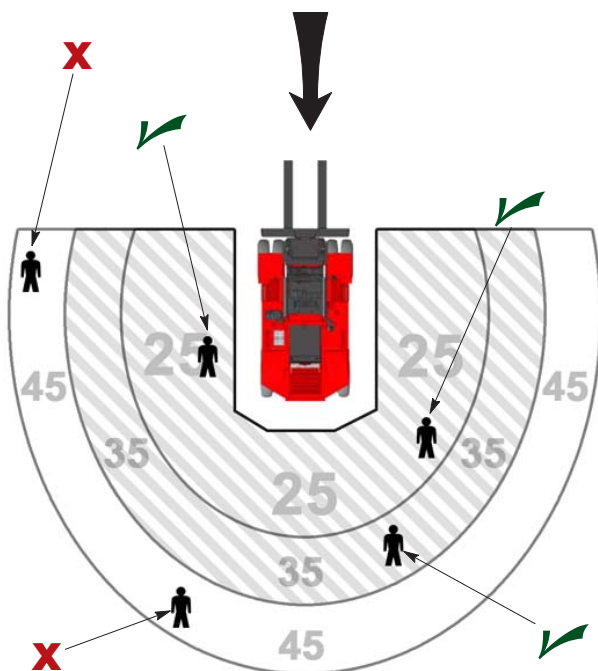

**NEUTRAL**  
(25FT COVERAGE AREA RADIUS)

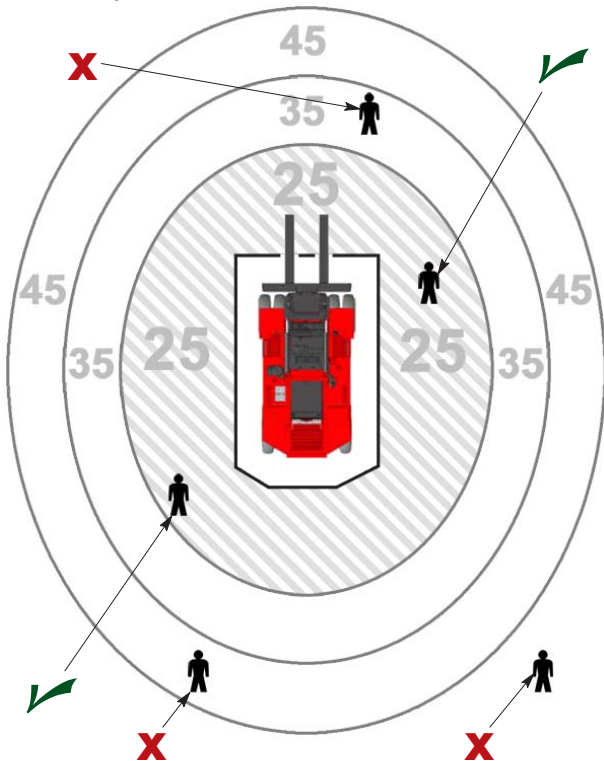

---

## Introduction

The Vision Plus™ pedestrian detection aid is a system designed to aid the operators of mobile machinery in the location of pedestrians in the vicinity of the vehicle. This manual is intended to provide the operator with instructions on how to use the system properly. Because the operator is so vital to safety and production, these instructions contain important information concerning proper operation of the Vision Plus™ system first. This safety information must be understood before operation. No single piece of information in this manual can be used with the exclusion of the others. This manual must be read in its entirety. Additionally, these instructions cannot cover all circumstances that may be encountered.

No one safety device is perfect and can cover all possible situations. Remember! The most important safety device on the machine is you – the operator. Always look in the direction of and keep a clear view of the path of travel.

 **WARNING:** Death or serious injury may occur by improper operation. Do not operate this system until you have read and understand all operating instructions and safety information.

## End User Terms Of Use

PLEASE READ THE USER MANUAL AND THE IMPORTANT SAFETY INSTRUCTIONS AND WARNINGS BELOW CAREFULLY BEFORE INSTALLING OR USING VISION PLUS™ ("Product").

**By Installing Vision Plus™, you will be acknowledging and agreeing to operate the Product in accordance with the Safety Instructions and Warnings set forth below. If you do not agree to these terms, please return the Product to your dealer, in its original packing materials, within 30 days of purchase, for a full refund.**

### Safety Instructions

Installation must be carried out by an Authorized Vision Plus™ Product Dealer or Installer.

Vision Plus™ should not be transferred between vehicles, other than by an Authorized Vision Plus™ dealer or installer.

### Vision Plus™ Dealer or Installer

The Product should only be operated with 12VDC ~24VDC power.

Do not cover or obstruct the Vision Plus™ camera or the display unit.

Do not use the system for any purpose other than as described in the User Manual.

## WARNINGS:

**A.** Vision Plus™ is a driver assistance system which is intended to alert drivers of certain potentially dangerous situations. It does not replace any functions drivers would ordinarily perform in driving a motor vehicle, nor does it decrease the need for drivers to stay vigilant and alert in all driving conditions, to conform to all safe driving standards and practices, and to obey all traffic laws, rules and regulations.

**B.** Vision Plus™ is not an automated driving system and it does not act as a substitute for any aspect of driver vehicle control or safe driving practices. Drivers are strongly cautioned not to rely on Vision Plus™ as a replacement, to even the slightest degree, for exercising all due caution in assuring that they are driving safely and avoiding accidents.

C. While Vision Plus™ represents a state of the art innovation in machine vision software and other technologies, it cannot and does not guarantee 100% accuracy in the detection of pedestrians, vehicles or driving lanes, nor in providing warnings of all potential hazards. In addition, road, weather, and other conditions can adversely affect the Vision Plus™ system's recognition and response capabilities. Accordingly, drivers should not rely on the Vision Plus™ system to assure their driving safety, but rather should continue to rely on safe driving practices.

D. Drivers should exercise caution in using the Vision Plus™ Display Unit. Always maintain full concentration on keeping a clear travel path when referring to the Vision Plus™ Display Unit.

#### LIMITED USE LICENSE

1. TAYLOR hereby grants the original purchaser of Vision Plus™ ("Buyer"), a non-exclusive and non-transferable license to use the software embedded in the Product as supplied by TAYLOR, as well as the documentation accompanying the Product.

2. Buyer shall not: (a) modify, adapt, alter, translate, or create derivative works from any software residing within Vision Plus™ software provided by TAYLOR in conjunction with Vision Plus™, (b) reverse assemble, decompile, disassemble, or otherwise attempt to derive the source code for such software without written authorization from TAYLOR, (c) assign, sublicense, lease, rent, loan, transfer, disclose, or otherwise make available such software, or (d) remove proprietary notices on Product or Documentation.

#### IF WARRANTY SERVICE IS NEEDED

The following procedure is to be followed if a problem arises with Vision Plus™:

1. Contact the certified dealer/installer if Vision Plus™ was purchased from dealer.
2. Contact TAYLOR if Vision Plus™ was purchased directly from TAYLOR. A return authorization number is required and may be obtained by calling our Customer Service Dept. at (662) 773-8056.
3. Warranty service requires verification of ownership and date of purchase. Please submit the original invoice to establish ownership and date of purchase. If acceptable proof of purchase is not available for verification, the warranty period is deemed to have begun on the installation date or manufacturing date marked on the Vision Plus™ Product.

Nothing in this Agreement shall mean or be interpreted as reducing any of the Operator's responsibilities, nor would it mean to reduce any legal or other obligations of the Operator or vehicle owner to ensure the vehicle as is required by law or regulation and/or is generally accepted practice of such Operator or vehicle owner.

Read and submit this completed and signed form to an authorized Vision Plus™ dealer. Additional information may be required. Thank you for considering Vision Plus™.

For questions or comments regarding operation or maintenance of the Vision Plus™ system, please contact:

**SUDDEN SERVICE, INC.**  
649 North Church Avenue  
Louisville, MS 39339-2017 USA  
Phone (662) 773-8056  
Fax (662) 773-9157  
Web Site: [www.taylorbigred.com](http://www.taylorbigred.com)



---

# Contents

|  |    |
|--|----|
| Safety .....                             | 1  |
| System Components .....                  | 3  |
| System Operation .....                   | 5  |
| Operator Display Module .....            | 6  |
| Zone Indicator Display (Optional) .....  | 11 |
| Pre-operational Check .....              | 15 |
| System Performance .....                 | 16 |
| In The Event Of A Detection .....        | 22 |
| Performance Verification Procedure ..... | 23 |
| Diagnostics .....                        | 27 |
| Options .....                            | 32 |

## **Appendices**

|  |    |
|--|----|
| A - Instructor's Guide for Vision Plus ..... | 35 |
| Limited Warranty .....                       | 43 |



---

## Safety

**⚠ WARNING**: Death or serious injury may occur from collisions. No device or alarm is perfect. Never depend on a safety device or alarm to clear the area of pedestrians. Be vigilant and always clear the path of travel with direct vision.

**⚠ WARNING**: Death or serious injury may occur from improper operation.

- Always follow equipment manufacturer's operation instructions and safety information.
- Read and understand all of the instructions included in this booklet before operating the Vision Plus™ system.
- Always perform a visual check of the cameras prior to equipment operation.
- Always use direct vision in conjunction with the Vision Plus™ system.
- Always ensure the system passes the startup test before continuing with use of the system.
- Do not rely on the system if a system disabled warning or active warning cannot be cleared. Notify the appropriate maintenance technician.

**⚠ WARNING**: Death or serious injury may occur from failure to clear the path of obstacles with direct vision. The Vision Plus™ system will only detect pedestrians. Warning information will not be given for any obstacle other than pedestrians. Always keep a clear view of the path of travel.

**⚠ WARNING**: Death or serious injury may occur from failure to use the Vision Plus™ system properly. The system may be adversely affected by severe weather conditions, differing lighting conditions, dark shadows, or other conditions that may obstruct the view of pedestrians. REMEMBER – the system can only detect pedestrians that can be "seen" by the cameras.

**⚠ WARNING**: Death or serious injury may occur from using a system affected by damage. The Vision Plus™ system performance can be affected by damage to the cameras, camera mounts, the vehicle, or components being misaligned or misadjusted. Always perform a daily visual check to ensure the cameras are not damaged or misaligned.

**⚠ WARNING**: Death or serious injury may occur from ignoring the warning information provided by the Vision Plus™ system. When the audible and/or visual warning information is provided, slow down if necessary, identify the area around the vehicle where the pedestrian has been detected, and immediately clear that area with direct vision.

**⚠ WARNING**: Death or serious injury may occur from improper operation of the vehicle. Do not attempt to make adjustments or operate the functions of the Vision Plus™ display while the vehicle is in operation. Bring the vehicle to a complete stop and set the parking brake before operating the functions of the Vision Plus™ display.

**⚠ WARNING**: Death or serious injury may occur from improper operation. Understand that the normal detection range of the system is approximately 45 feet. Traveling at high speeds requires increased awareness because the time and distance required to stop the vehicle increase. There may be specific conditions, such as operating the vehicle loaded at high speeds where the distance required to stop the vehicle can be greater than the maximum detection range. Always keep a clear view of the path of travel and be aware of the distance required to bring the vehicle to a stop in the event of a detection.

**⚠ WARNING**: Death or serious injury may occur from failure to clear the area before truck operation. The Vision Plus™ system is a direct line-of-sight system.

- The system can only locate pedestrians who are upright and walking or standing.
- The system can only locate pedestrians who can be "seen" by the cameras.
- Ensure areas behind loads or other obstructions are clear before operating.
- Attachments and loads which are lowered in front of the forward cameras will block the detection capability of those cameras. Any obstruction positioned in front of any camera will block the detection by that camera.
- Ensure both work area lighting and vehicle lighting are adequate. System performance will be reduced in poor lighting conditions.

---

## System Components

The Vision Plus™ system is comprised of multiple cameras – located in various positions on the vehicle, a display located in the operator cabin, and other various electrical components.

### Cameras

To operate correctly, the cameras of the Vision Plus™ system must never be removed or re-positioned in any way from the location and position in which they were first installed and adjusted by the authorized installer.

#### *Cameras*



The cameras act as the “eyes” of the system. These cameras are housed in weathertight enclosures behind a sealed glass. This glass must be maintained and cleaned regularly using a soft cloth. Some systems are installed with an optional polycarbonate shield which may need to be replaced over time due to blurriness or excessive scratches.

**⚠ WARNING:** The system can be rendered inoperable if the camera enclosure glass or shield is not cleared of debris, grease, dirt, etc., or if scratching is excessive.

The camera assembly is not serviceable and must not be opened or removed from its original location at any time. Contact qualified maintenance personnel for troubleshooting, or your qualified Vision Plus™ dealer for replacement.

In the event that one or more of the cameras becomes inoperable due to mechanical or electrical malfunction, a warning will be issued to the operator by way of the operator display located in the operator cabin. See System Operation on page 6 for further instructions. If the error cannot be resolved, discontinue use of the system and report the malfunction to the appropriate maintenance personnel.

**⚠ WARNING:** While the Vision Plus™ system can detect on its own when a camera is malfunctioning, the system cannot detect on its own a misaligned camera.

Familiarize yourself with the proper alignment of the cameras so that it will be more likely that a problem can be noticed during the pre-operational check. Loose bolts, damaged brackets, damaged mounting surfaces, and scratched paint could be indicators that a camera should be checked for alignment problems.

*Mis-alignment Due To Parts Damage*

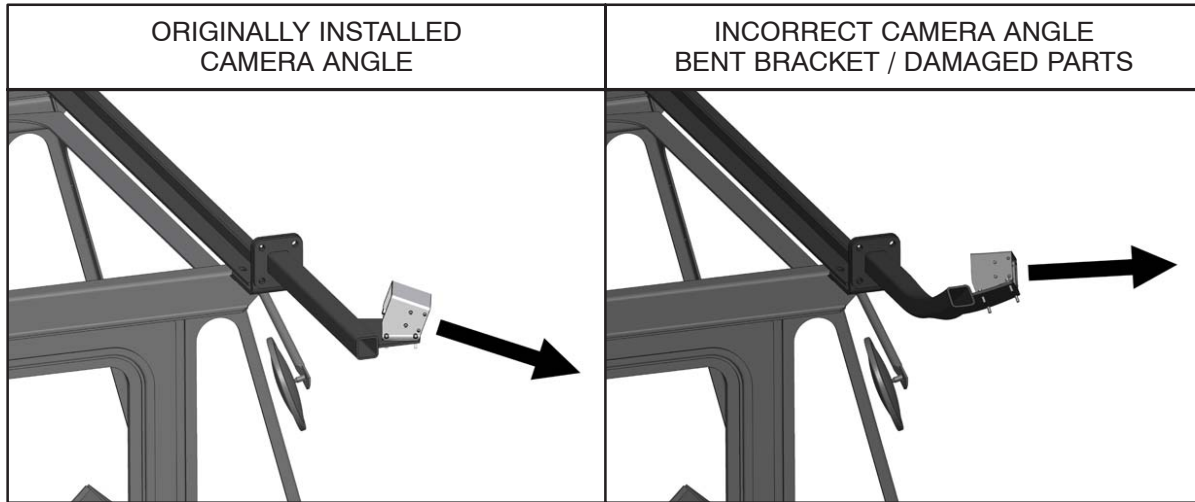

If the vehicle will be used at night or in areas with poor lighting, ensure the vehicle worklights are adequate and operational. Ensure the area in which the machine will be operated has adequate lighting. Performance can be verified using the procedure as outlined in the **Performance Verification Procedure** section of this manual. Ensure the verification test is performed in the same lighting conditions in which the vehicle will be operated.

---

## System Operation

**⚠ WARNING:** Death or serious injury may occur from improper training. Read, understand, and follow all operating rules found in the Vision Plus™ user guide.

**⚠ WARNING:** Death or serious injury may occur from improper operation of the vehicle. Do not attempt to make adjustments or operate the functions of the Vision Plus™ display while the vehicle is in operation. Bring the vehicle to a complete stop and set the parking brake before operating the functions of the Vision Plus™ display.

**NOTE:** The screens illustrated in this manual are for typical coverage areas which may vary. The exact layout of the detection zones may be different than these illustrated.

### Display Types

The Vision Plus™ system is operated using information provided by the display located in the operator compartment.

The Vision Plus™ system utilizes one of two possible display types:

1. Operator Display Module
2. Zone Indicator Display

A separate section is provided for operation of each display type.

### Display Types



---

## Operator Display Module

Depending on the type of equipment on which the Vision Plus™ system is installed, the display can vary. Equipment which does not incorporate a specific type of control system will be supplied with a “stand-alone” operator display module (see Illustration).

The operator display module, located in the operator’s cabin, provides real-time information to the operator of the vehicle concerning locations of pedestrians in the area around the vehicle. Additionally, the operator display module will provide diagnostics and troubleshooting information (refer to **Maintenance and Troubleshooting** section).

### *Operator Display Module*

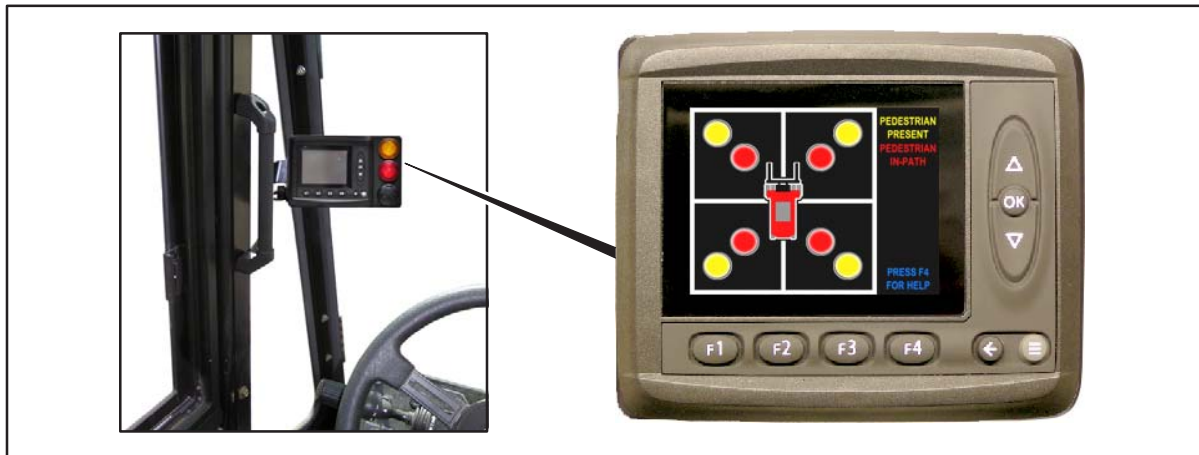

There are buttons located on the operator display which are used for making selections on the different display screens.

### *Audible Alarm*

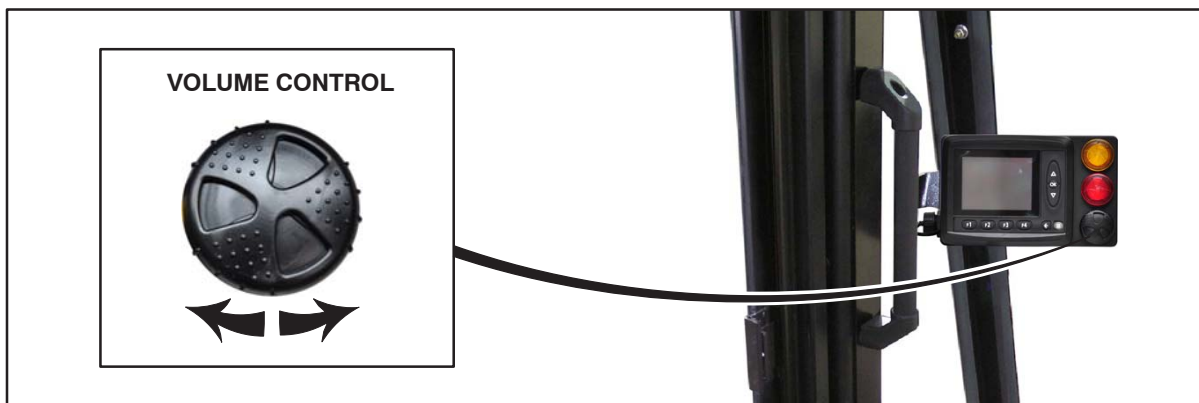

A manually adjustable audible alarm is located beside the operator display module. The alarm loudness can be adjusted within a specific range by turning the bezel.

The alarm loudness should be adjusted such that the alarm can be heard by the operator during all machine operations.

**⚠ WARNING:** Ability to hear the audible alarm may be affected by machine operations. Some machine operations produce more noise than others. Before operation, ensure the audible alarm is adjusted so that it can be heard under all possible machine operations. Ensure the audible alarm is adjusted while understanding that hearing capabilities between operators can differ.

### Power On / Off

The Vision Plus™ system is powered on and off using the vehicle key switch. Turn the vehicle key switch to the ON position to power the system on. Turn the vehicle key switch to the OFF position to turn the system off.

### System Start Up Screen

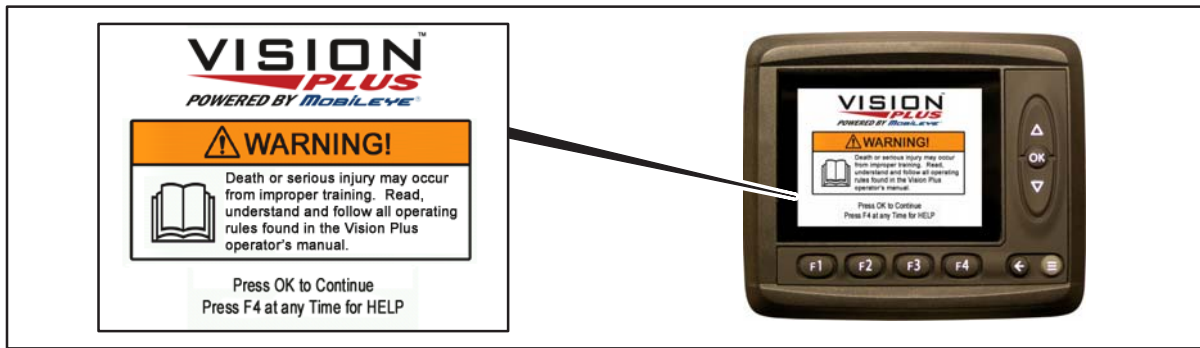

After powering the system on by way of the vehicle key switch, the Vision Plus™ system displays the System Start Up Screen. This screen provides important information to the operator. Press the (OK) button located on the operator display to continue.

### System Check Screen

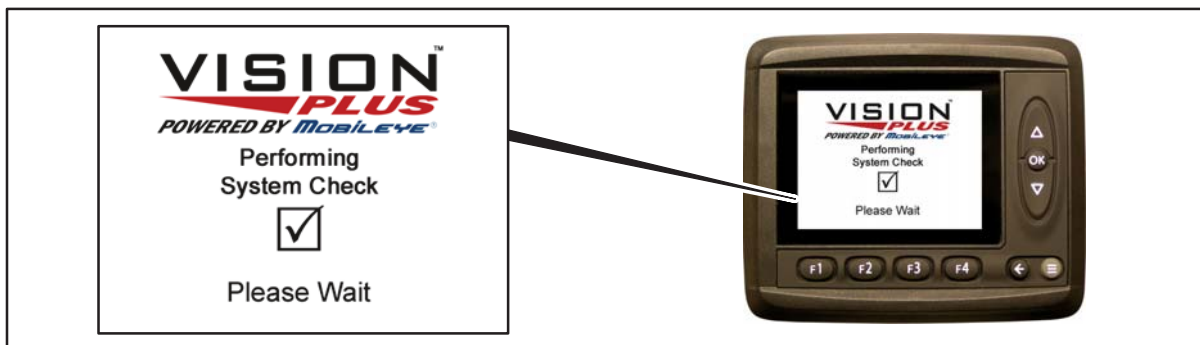

Once the (OK) button has been pressed, the system will enter a system check procedure. During this check, proper function will be checked for all cameras in the system. The zones will flash in sequence and the audible alarm will sound to indicate proper operation.

## Normal System Operation Screen

Once the system has performed all of the internal checks, the operator display will automatically proceed to the Normal System Operation Screen.

**NOTE:** The screens illustrated in this manual are for typical coverage areas which may vary. The exact layout of the zones may be different than these illustrated.

### Normal System Operation Screen

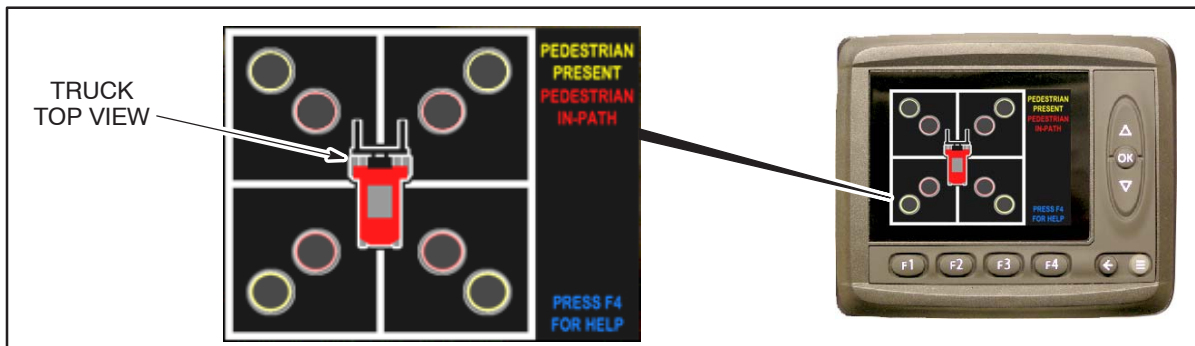

The Normal System Operation Screen displays an overall top view of the vehicle and the area around the vehicle separated into zones. The layout of the zones can vary depending upon installation.

### Typical Detection Zones

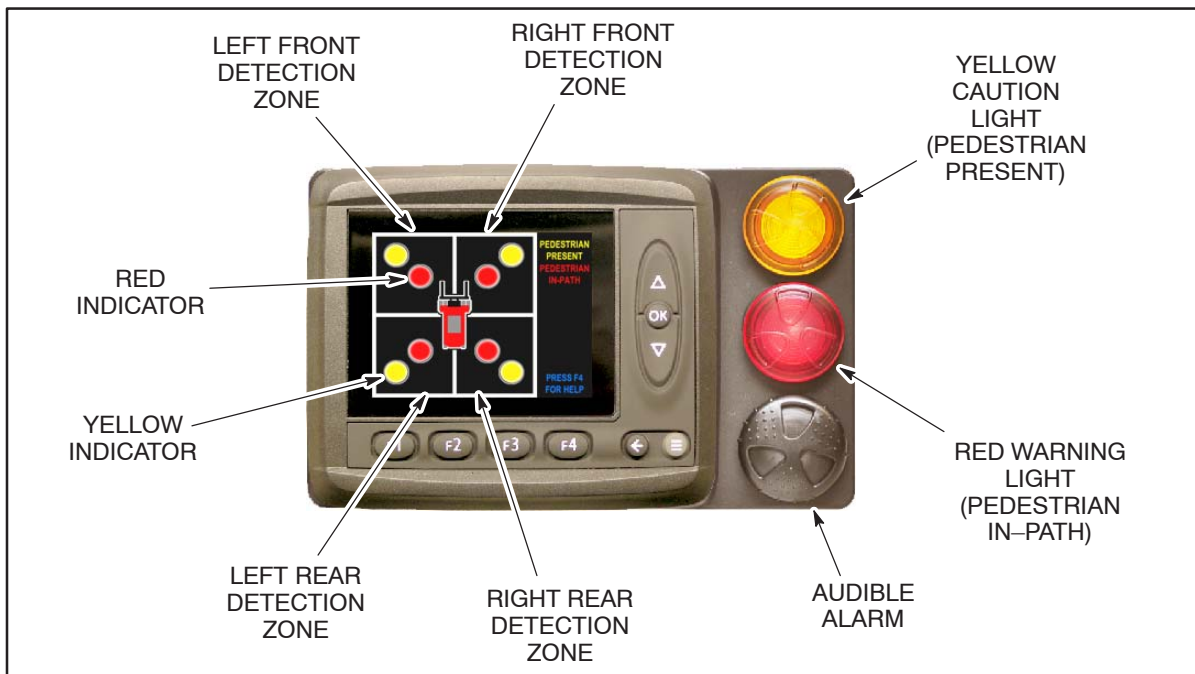

In the event that a pedestrian is detected, a visual alarm will be activated by an indicator on the zone in which the pedestrian is located. Additionally, an audible alarm will sound.



## Warning Types

The Vision Plus™ system has the capability of locating and tracking the detected pedestrian(s). Additionally, the Vision Plus™ system has the capability of tracking the movement of the equipment. Using these capabilities, the Vision Plus™ system can determine whether or not the paths of the equipment and pedestrian(s) could cross. These two possibilities (paths do not cross and paths may cross) enable the system to provide two distinct warning types to the operator.

### 1. Pedestrian Present. Paths will not cross.

A pedestrian has been located in one or more of the coverage area zones. Either the machine is not moving or the paths of the machine and pedestrians do not cross. In this case, the operator display will illuminate the yellow indicator in which the pedestrian(s) has been located. Additionally, an audible alarm will sound at approximately one "beep" every two seconds and the yellow "Caution" light will illuminate.

**⚠ WARNING:** Death or serious injury may occur from collisions. In the event the Vision Plus™ system provides a warning for pedestrians present, slow down if necessary, immediately locate the pedestrian or pedestrians with direct vision. Always keep a clear view of the path of travel.

### 2. Pedestrian In-path. Paths will cross.

Pedestrian(s) within the coverage area may be moving in a direction that could cross the path of the vehicle or may be standing in the path of the moving vehicle. In the event that the potential paths of the vehicle and a pedestrian cross, or a pedestrian is standing in the path of the moving vehicle, the system will flash the red indicator on the zone in which the pedestrian is located. Additionally, an audible alarm will sound at approximately two "beeps" per second and the red "Warning" light will flash.

**⚠ WARNING:** Death or serious injury may occur from collisions. In the event the Vision Plus™ system provides a pedestrian in-path warning, slow down and immediately locate the pedestrian or pedestrians with direct vision. Be prepared to take corrective actions if necessary. Always keep a clear view of the path of travel. Always understand that the distance and time required to stop the vehicle is greatly affected by vehicle speed.

**⚠ WARNING:** Death or serious injury may occur from collisions. Always ensure tailswing area is clear. Detections in the rear zones may indicate a pedestrian in the tailswing area. Always clear both the area directly behind the vehicle and the tailswing area when a rearward detection occurs.

## System Malfunction

When there is a system malfunction or there is an internal issue with one of the cameras, a System Disabled Maintenance Screen will be automatically displayed on the operator display module. If this condition occurs, the red indicator light on the operator display module will flash continuously. Refer to Diagnostics section of this guide.

### *System Disabled Screen*



---

## Zone Indicator Display (Optional)

Depending on the type of equipment on which the Vision Plus™ system is installed, the display can vary. Equipment which is manufactured by Taylor Machine Works, Inc. (Taylor®) and which incorporates a specific type of control system (Taylor TICS) will be supplied with a zone indicator display (see Illustration).

The zone indicator display, located in the operator's cabin, provides real-time information to the operator of the vehicle concerning locations of pedestrians in the area around the vehicle by way of a system of LEDs (see Illustration). The zone indicator display works in conjunction with the existing vehicle system control module (TICS).

### *Zone Indicator Display*



### *Audible Alarm*

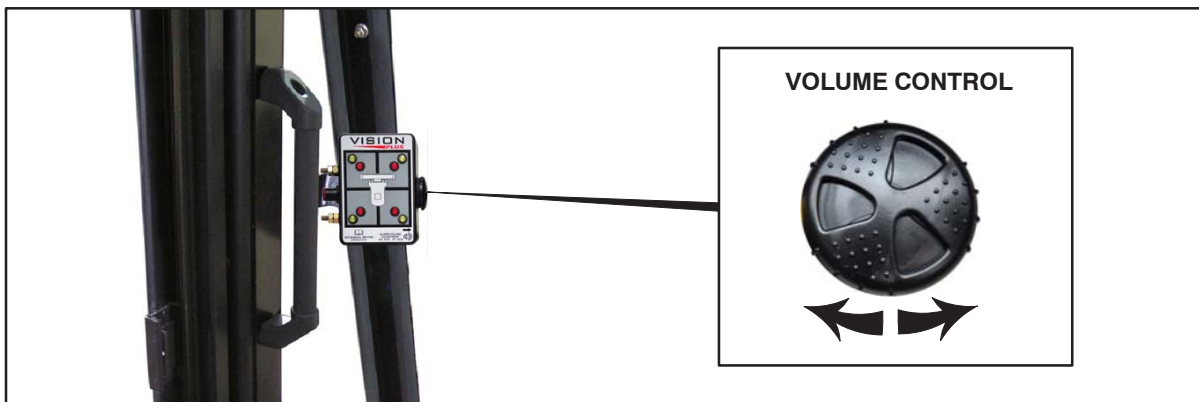

A manually adjustable audible alarm is located on the righthand side of the zone indicator. The alarm loudness can be adjusted within a specific range by turning the bezel. The alarm loudness should be adjusted such that the alarm can be heard by the operator during all machine operations.

**⚠ WARNING:** Ability to hear the audible alarm may be affected by machine operations. Some machine operations produce more noise than others. Before operation, ensure the audible alarm is adjusted so that it can be heard under all possible machine operations. Ensure the audible alarm is adjusted while understanding that hearing capabilities between operators can differ.

### Power On / Off

The Vision Plus™ system is powered on and off using the vehicle key switch. Turn the vehicle key switch to the ON position to power the system on. Turn the vehicle key switch to the OFF position to turn the system off.

### System Check

Immediately after the system has been powered on, the system will enter a system check procedure. During this check, proper function will be checked for all cameras in the system. The LED's will flash in sequence and the audible alarm will sound to indicate proper system operation.

**NOTE:** The illustrations in this manual are for typical coverage areas which may vary. The exact layout of the zones may be different than those illustrated.

### Typical Detection Zones

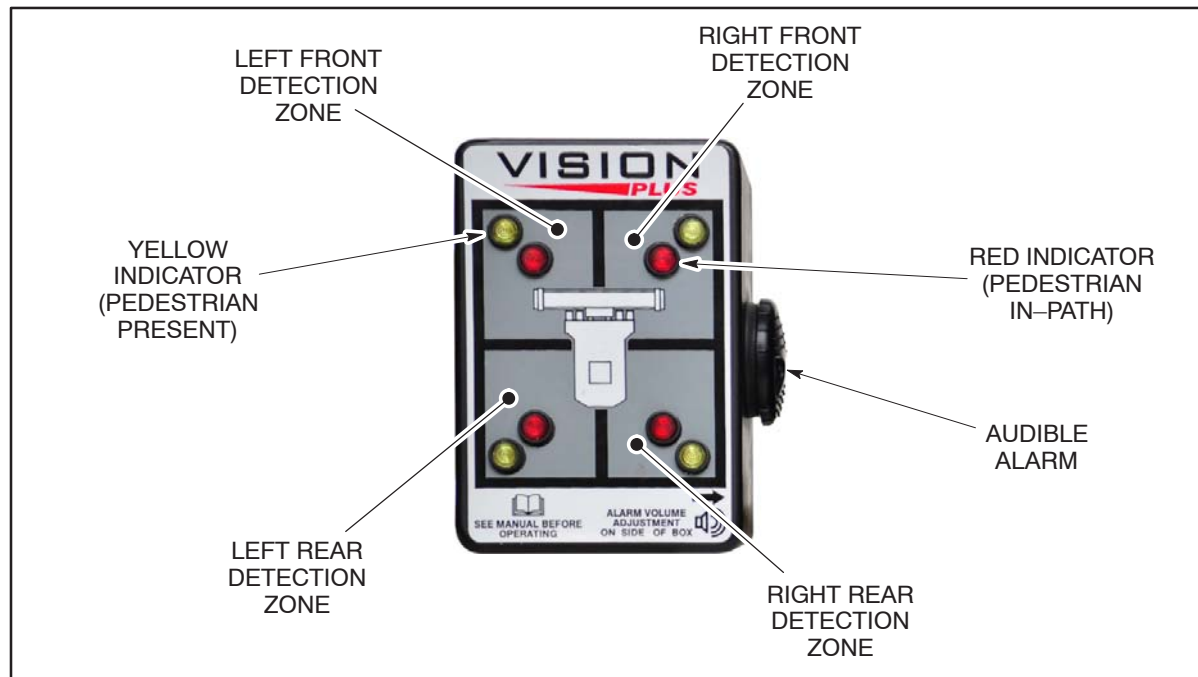

## Normal System Operation

In the event that a pedestrian is detected, a visual alarm will be activated by illuminating the indicator in the zone in which the pedestrian is located. Additionally, an audible alarm will sound.

### Normal System Operation Screen

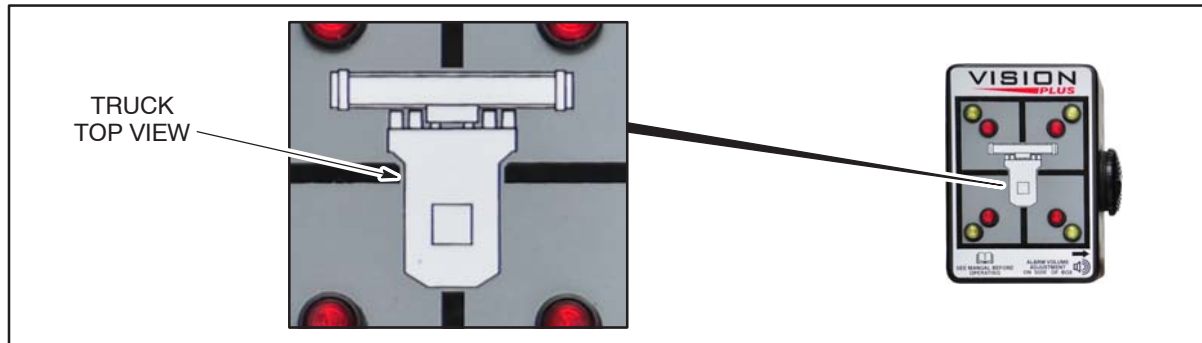

## Warning Types

The Vision Plus™ system has the capability of locating and tracking the detected pedestrian(s). Additionally, the Vision Plus™ system has the capability of tracking the movement of the equipment. Using these capabilities, the Vision Plus™ system can determine whether or not the paths of the equipment and pedestrian(s) could cross. These two possibilities (paths do not cross and paths may cross) enables the system to provide two distinct warning types to the operator.

### 1. Pedestrian Present. Paths will not cross.

A pedestrian has been located in one or more of the coverage area zones. Either the machine is not moving or the paths of the machine and pedestrians do not cross. In this case, the zone indicator display will illuminate the yellow indicator on the zone(s) in which the pedestrian(s) has been located. Additionally, an audible alarm will sound at approximately one "beep" every two seconds.

**⚠ WARNING**: Death or serious injury may occur from collisions. In the event the Vision Plus™ system provides a warning for pedestrians present, slow down if necessary, immediately locate the pedestrian or pedestrians with direct vision. Always keep a clear view of the path of travel.

### 2. Pedestrian In-path. Paths will cross.

Pedestrian(s) within the coverage area may be moving in a direction that could cross the path of the vehicle or may be standing in the path of the moving vehicle. In the event that the potential paths of the vehicle and a pedestrian cross, or a pedestrian is standing in the path of the moving vehicle, the system will flash the red indicator on the zone in which the pedestrian is located. Additionally, an audible alarm will sound at approximately two "beeps" per second.

**⚠ WARNING**: Death or serious injury may occur from collisions. In the event the Vision Plus™ system provides a pedestrian in-path warning, slow down and immediately locate the pedestrian or pedestrians with direct vision. Be prepared to take corrective actions if necessary. Always keep a clear view of the path of travel. Always understand that the distance and time required to stop the vehicle is greatly affected by speed.

**⚠ WARNING**: Death or serious injury may occur from collisions. Always ensure tailswing area is clear. Detections in the rear zones may indicate a pedestrian in the tailswing area. Always clear both the area directly behind the vehicle and the tailswing area when a rearward detection occurs.

### System Malfunction

When there is a system malfunction or there is an issue with one of the cameras, an active warning will be automatically displayed on the TICS display module. If this condition occurs, the red indicator LEDs on the zone indicator display will flash. Refer to Diagnostics section of this guide.

#### Active Camera Errors & Zone Indicator Display



---

## Pre-operational Check

**⚠ WARNING:** Death or serious injury may occur from operating the Vision Plus™ system with cameras that are damaged, misaligned or malfunctioning. While the Vision Plus™ system can detect on its own when a camera is malfunctioning, the system cannot detect on its own when a camera is misaligned. Always perform a pre-operational check of the cameras before operating the vehicle.

Always perform a pre-operational check of the cameras before operating the Vision Plus™ system. The Vision Plus™ systems relies on proper camera alignment and mounting for correct operation. The pre-operational visual inspection should consist of the following:

- ☑ Visually check the cameras to ensure they are in place and properly aligned. Familiarize yourself with the proper alignment of the cameras so that it will be more likely that a problem can be noticed. Loose bolts, damaged brackets, damaged mounting surfaces and scratched paint could be indicators that a camera should be checked for alignment problems.
- ☑ Visually check the cameras to ensure they do not have obvious damage to the cameras, mounts or wiring.
- ☑ Visually inspect the camera lens on each camera unit to ensure it is clean. Clean if necessary. Use only mild cleaners and a soft cloth to reduce the possibility of scratching the glass or shield (if equipped).
- ☑ On systems installed with the optional polycarbonate shield, visually inspect the shield on each camera unit to ensure it is clean. Excessive scratches will decrease system performance. Replace the shield with a new shield when scratches are visible.
- ☑ Visually inspect the cameras and the areas around the cameras to remove loose debris that may cover the camera or block its view.
- ☑ If the equipment is to be operated at night or in low light areas, ensure the equipment's worklights are installed and functional. Ensure the area where the machine is to be operated has adequate lighting.
- ☑ Damaged brackets, operational but mis-aligned cameras, debris, etc. can all affect the performance of the system and, in some cases, go unnoticed by the system's internal checks. Never use the system if you suspect some parts are damaged or mis-aligned. Never use the system when it does not operate as expected. Contact the appropriate service personnel.

# System Performance

**⚠ WARNING:** Death or serious injury may occur from collisions. No device or alarm is perfect. Never depend on a safety device or alarm to clear the area of pedestrians. Be vigilant and always clear the path of travel with direct vision.

In combination with the operator's direct vision, the Vision Plus™ system can aid in the location of pedestrians in the area around the vehicle. There are basic operational characteristics of the system that must be understood before using Vision Plus™.

## Typical Detection Ranges

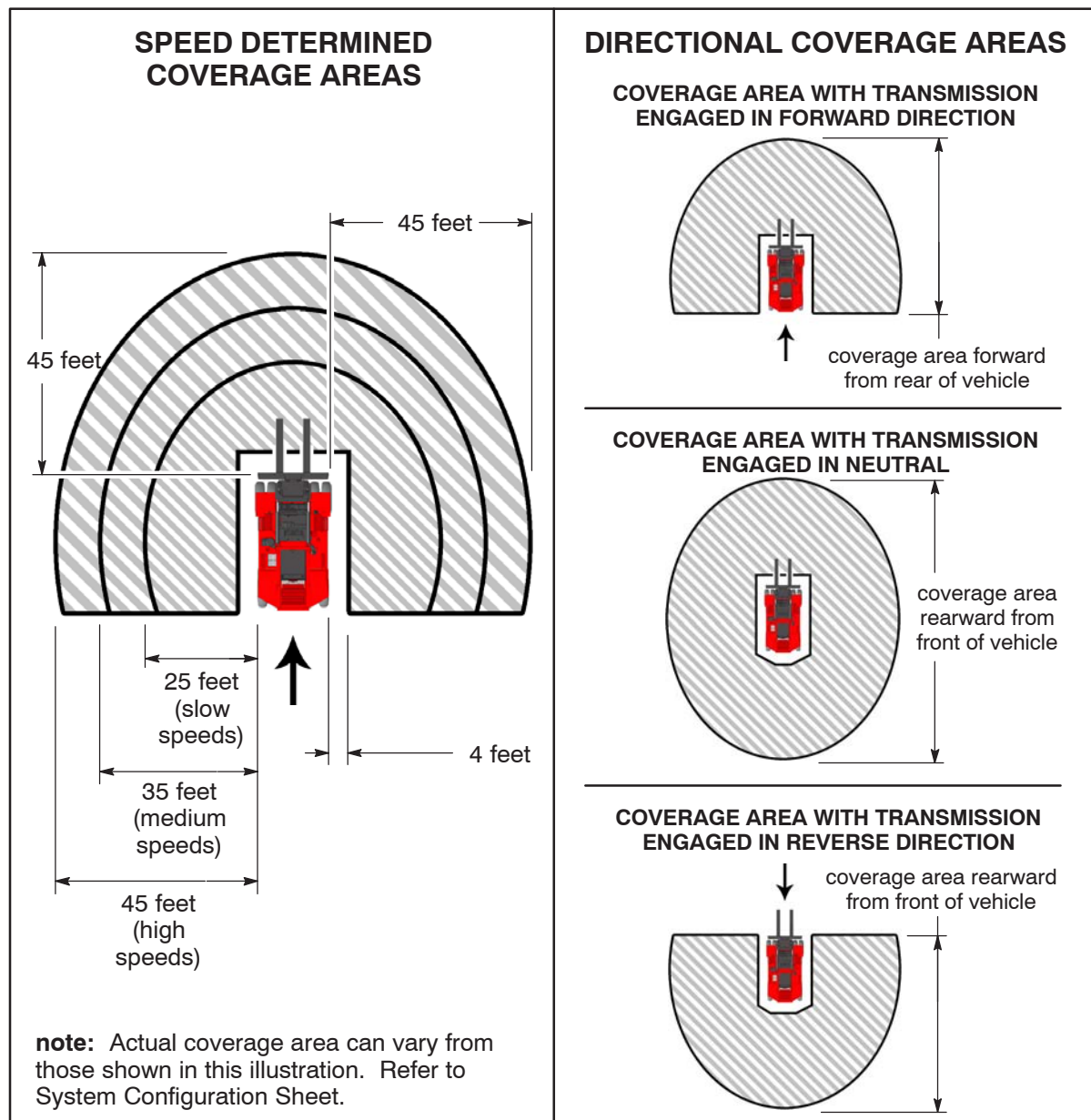



## Coverage Area

In general, the total system coverage area is made up of the combination of individual camera coverage areas. The system coverage area is only the combined areas that can be “seen” by the individual cameras. Familiarize yourself with the particular system installation on your vehicle to understand the areas covered by the cameras. Some systems cover the entire perimeter of the vehicle while some systems cover only portions of the area around the vehicle. Refer to the separate System Configuration Sheet for specific information concerning the coverage area on your vehicle.

Measuring from the outline of the machine chassis, the area of coverage around the vehicle begins at approximately 4 feet and reaches out to approximately 45 feet. Due to varying application requirements, the shape of the coverage area can vary significantly. The maximum coverage area varies with vehicle speed. In general the maximum distance covered by the system is 25 feet at slow speeds, 35 feet at medium speeds, and 45 feet at high speeds. As it is with the operation of all mobile equipment, the operator must always understand the stopping capabilities of the equipment. Additionally, consideration is required for the effects of vehicle speed on the operator’s ability to react and to bring the vehicle to a stop. Traveling at high speed requires increased awareness because the time and distance required to stop the vehicle increases. There may be specific conditions, such as operating the vehicle loaded at high speeds (greater than 12 mph), where the distance required to stop the vehicle can be greater than the maximum detection range (45 feet). Always keep a clear view of the path of travel, be aware of the distance required to bring the vehicle to a stop, and be prepared to maneuver the vehicle, if necessary, to avoid collisions.

On some vehicles, depending on configuration, vehicle direction can limit the maximum coverage area. In the forward direction, the coverage area only includes detections in front of and on both sides of the vehicle. In the reverse direction, the coverage area only includes detections behind and on both sides of the vehicle. It is extremely important that the operators know and understand the coverage area for the specific system on the machine they are to be operating and to understand the areas covered and not covered by the system. Refer to illustration **Typical Detection Ranges**, on previous page, for coverage area examples, and the separate System Configuration Sheet for specific information concerning the coverage area on your vehicle.

## Detectability

The Vision Plus™ system is a **line-of-sight system**. This means that only pedestrians within the direct view of the cameras can be detected. Simply put, each camera in the Vision Plus™ system acts as an extra set of eyes viewing the area around the equipment from the positions at which the cameras are mounted. If the view from the camera position to a pedestrian is blocked or partially blocked, more than likely, the pedestrian cannot be detected or “seen” by the camera or the system. If you could not see a pedestrian with your own eyes from the position that the camera is mounted, more than likely, the camera cannot see the pedestrian either and a warning will not be given.

## Missed Detections

There are specific conditions which can occur during machine operations which could cause the Vision Plus™ system to miss detecting a pedestrian. It is very important the operator understand these conditions and use the system accordingly.

## Obstructions:

The system cannot "see" through obstructions such as containers, barriers or vehicles. For example, the necessity of the lift truck to pick and place loads in front of the vehicle creates a situation where the load will, at times, obstruct the forward cameras. Additionally, objects between pedestrians and the truck can obstruct the full view of the pedestrian. These specific instances where obstructions block the detections of the cameras require increased awareness by the operator to ensure – as in all situations – that the area has been cleared by direct vision before and during the times the equipment is operated in that area. See the following illustrations:

### *Load Obstructions*

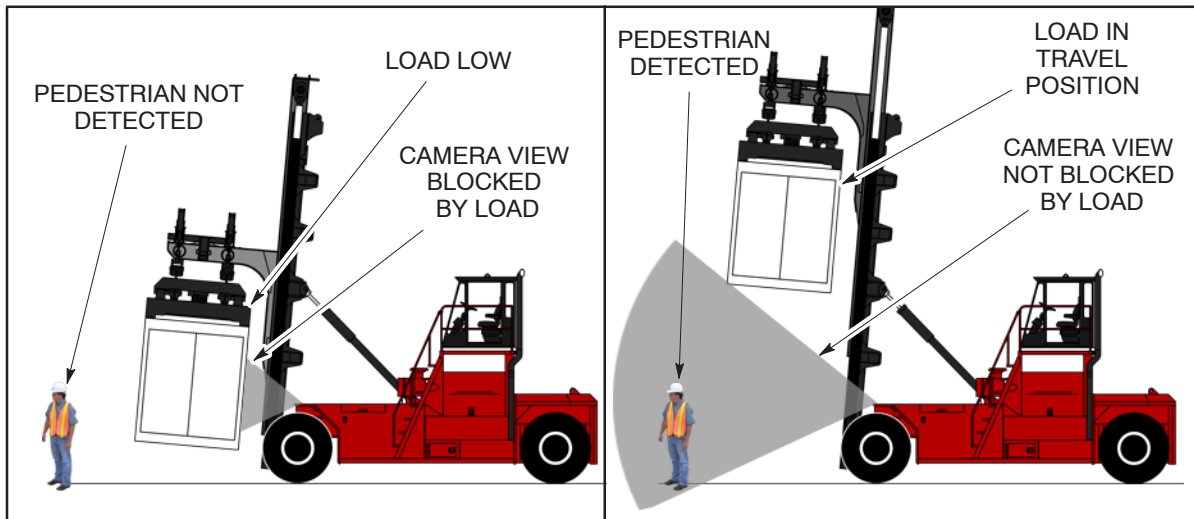

### *Obstructions*

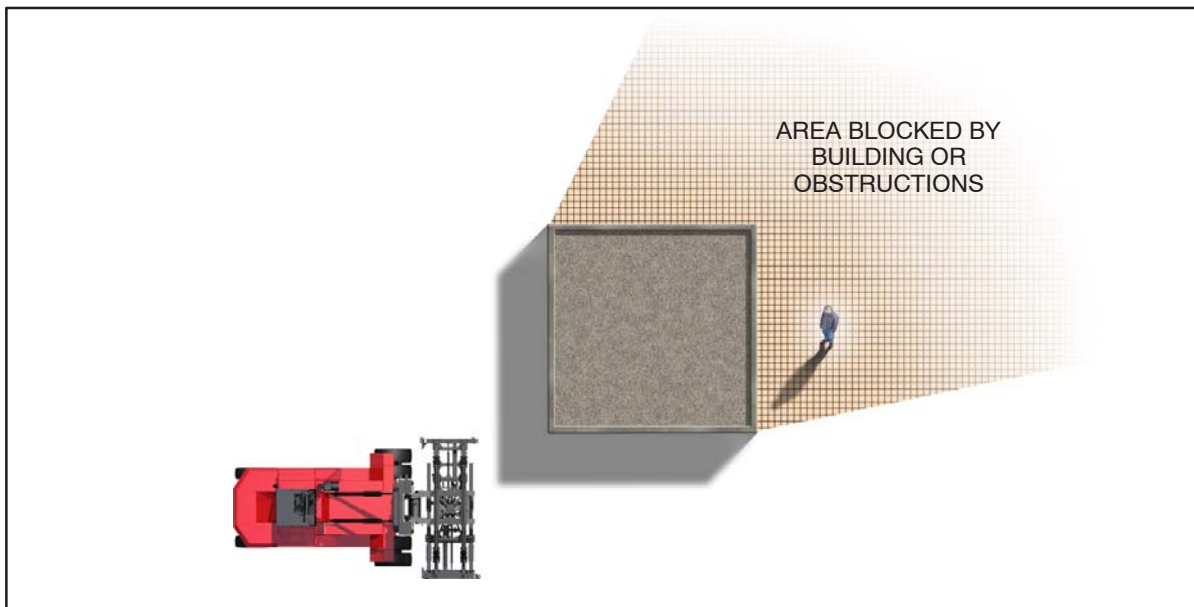

Body Position:

The Vision Plus™ system relies on images and shapes to determine if a pedestrian is in the coverage area. Under normal circumstances, the Vision Plus\_ system only detects pedestrians who are upright and standing or walking. There may be instances when a pedestrian is in a body position which will not allow the system to recognize them as a pedestrian. Some examples of this are kneeling, lying down, or leaning against an object. In these instances, the pedestrian may go undetected. See the following illustrations.

*Body positions which may result in missed positions*

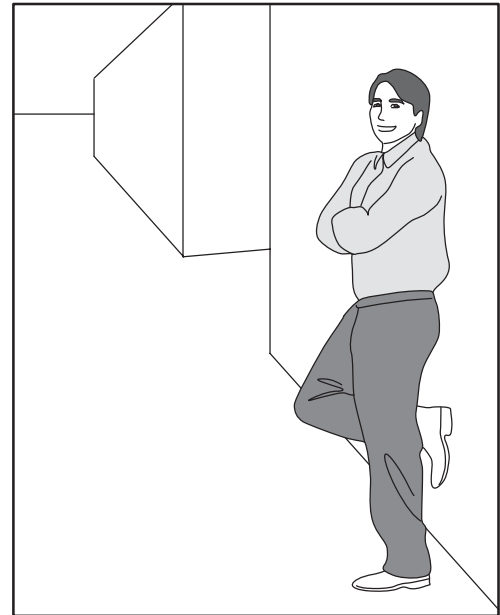

Extreme Weather Conditions:

Detection may also be affected by severe weather conditions which could include heavy rain, dense fog, snow, ice, etc. As an example, if weather conditions are severe enough to hinder the operator's direct vision, similarly, Vision Plus™ detection performance will be hindered.

*Blockage Due To Weather*

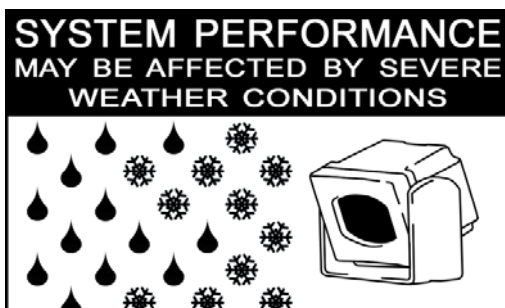

Lighting Conditions:

Detection may be affected by varying lighting conditions. An area too dark to see pedestrians with direct vision will also be too dark to detect pedestrians with the Vision Plus™ system. Always ensure work area lighting and worklights installed on the equipment are adequate to illuminate the coverage area during all operations.

### *Lighting Conditions*

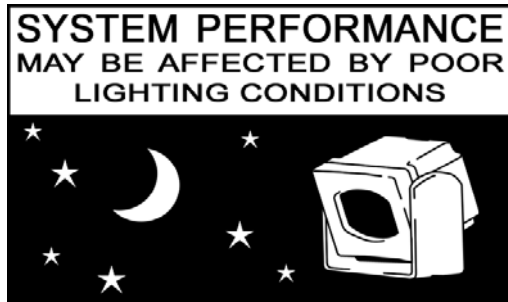

### **Late Detections Or Reduced Performance**

There are specific conditions which can occur during machine operations which could cause the Vision Plus™ system to detect pedestrians at a reduced range. It is very important the operator understand these conditions and use the system accordingly.

#### Shadows:

Under most operating conditions, pedestrians passing through shadows will not cause a decrease in performance. Although, there can be extremely abrupt changes from very light, bright areas to very distinct dark shadows which can cause a decrease in system performance. Slow down and use extra caution in these areas.

#### Environment Clutter:

The Vision Plus™ system is designed to be used in almost all environments. Although, there can be specific conditions where the pedestrian can “blend” into the background. This can be caused by high amounts of clutter in the environment or by pedestrians wearing unusually patterned clothing. Remember, if it is difficult to see a pedestrian with direct vision, more than likely, the system will have difficulty also.

## False Detections

Although the Vision Plus™ system drastically reduces the number of non-meaningful alarms to the operator, there are specific conditions when the system can return a false alarm. Objects in the environment which have similar shapes as pedestrians can cause the system to provide an alarm. See illustrations below:

*Objects which may result in false detections*

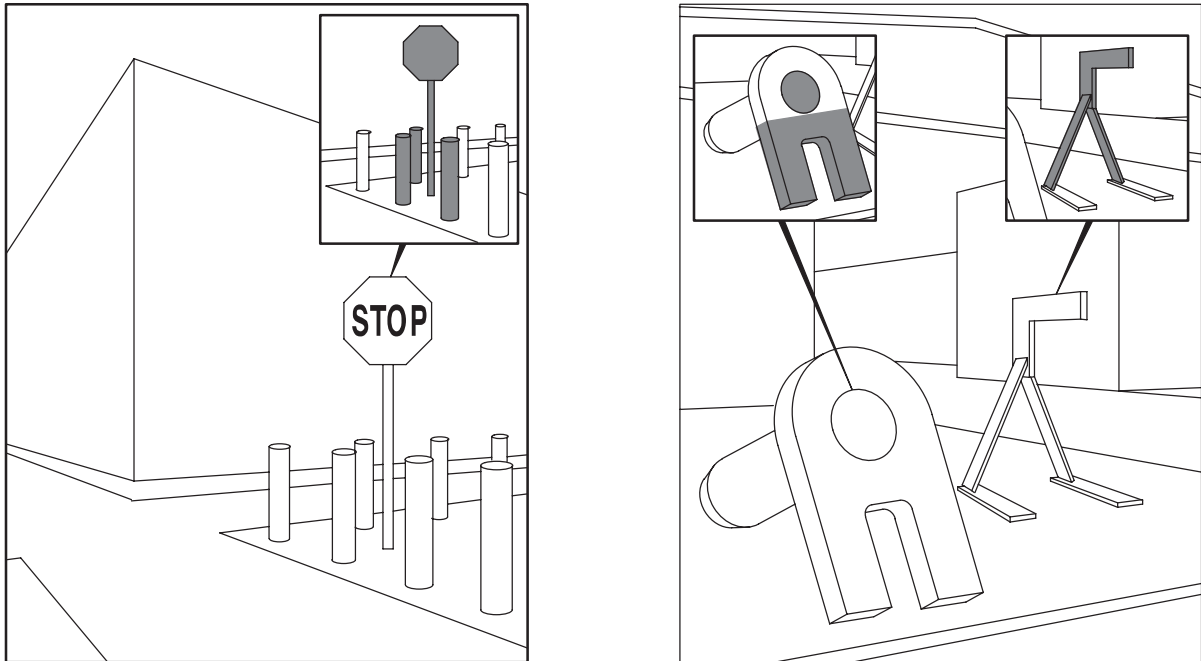

*No alarm should be ignored.* When an alarm is given, the operator must clear the area with direct vision. These types of false detections can be minimized by identifying objects in the environment which repeatedly return false detections and modifying their appearances.

## Performance Verification

Upon installations of the Vision Plus™ system, by an authorized dealer or installer, the performance was verified using a routine to check the detection by each camera. If at any time the performance is questioned or the system is not performing as expected, the performance verification procedure should be repeated before continuing to use the system. Additionally, the performance verification must be run at regular intervals. See the **Performance Verification Procedure** section of this manual for more information on the performance verification procedure.

---

## In The Event Of A Detection

**Pedestrian Present Warning** - In the event that the Vision Plus™ system gives a pedestrian present warning (yellow light), reference the zone or zones indicated by the display and indentify all pedestrians around the vehicle. Make eye contact with all pedestrians and ensure the pedestrians are aware of the machine. Sound the vehicle horn if necessary.

**Pedestrian In-path Warning** - In the event that the Vision Plus™ system gives a pedestrian in-path warning (red flashing light), be prepared to take corrective actions and quickly reference the zone or zones as indicated by the display. In-path warnings will be given in the following instances (see Illustration):

1. A non-moving pedestrian is in the path of a moving vehicle.
2. The paths of a moving pedestrian and a moving vehicle could cross.

An in-path warning will not be given if the vehicle is stationary or the path of a moving pedestrian is going away from the vehicle. In-path warnings require increased awareness of the pedestrian(s) and of the means necessary to stop the vehicle.

Ensure the path of travel is clear with direct vision before proceeding. Sound the vehicle horn if necessary. Ensure the pedestrian is aware of the vehicle.

### *In-path Warning Example*

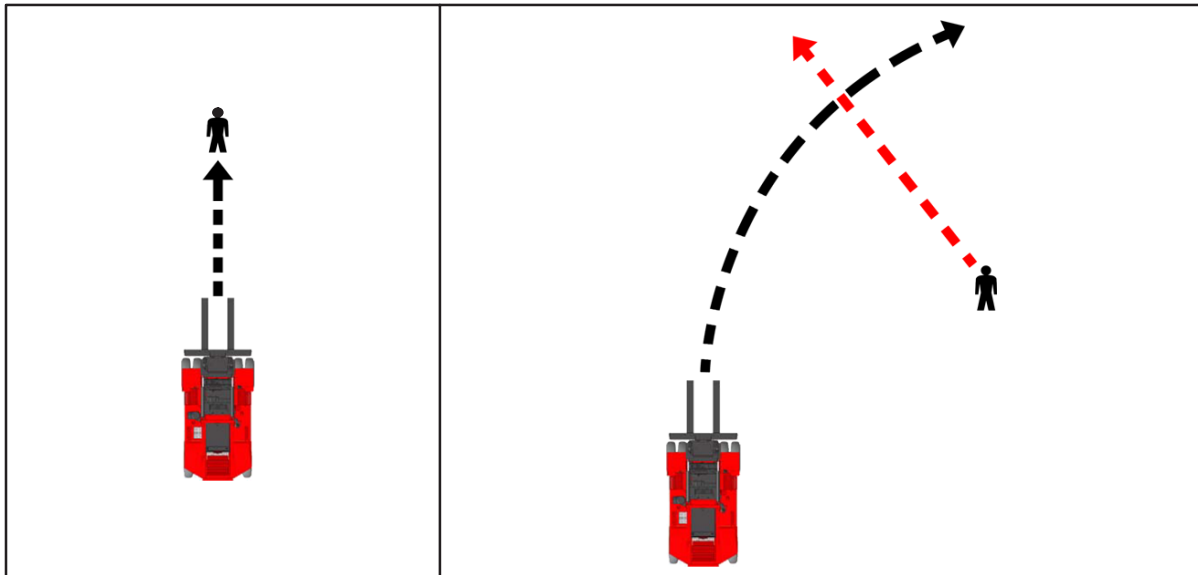

---

## Performance Verification Procedure

The Vision Plus™ system is equipped with a Performance Verification Procedure which is used by the authorized installer to verify proper camera operation. This procedure must also be used at regular intervals to check and re-verify that the system is operating properly. See the **Preventive Maintenance** section in this manual for more information on maintenance schedules. Additionally, the Performance Verification Procedure can be used at any time in the event the system is not performing as expected and to verify camera operation.

**⚠ WARNING:** Death or serious injury can occur from collisions. Do not use the Vision Plus™ system if the Performance Verification Procedure cannot be completed.

### *Performance Verification Screen*

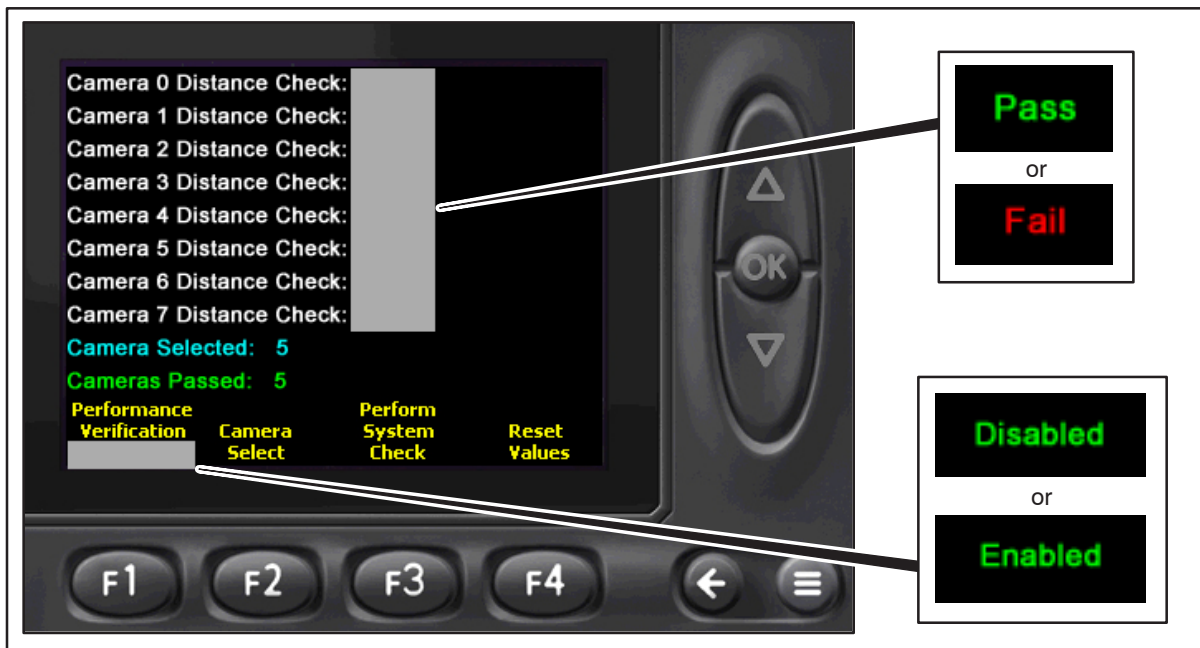

### **Performance Verification Screen**

The Performance Verification screen is accessed through the Vision Plus Options screen.

- For systems equipped with a system display module, select Options at the normal operating screen. Select Performance Verification.
- For systems equipped with a zone indicator display, the Performance Verification screen is accessed through the Taylor TICS Vehicle System Control Module. At the Main Screen, select Diagnostics. At the Diagnostics Screen select Vision Plus. Select Performance Verification.

### Testing Forward Facing Cameras

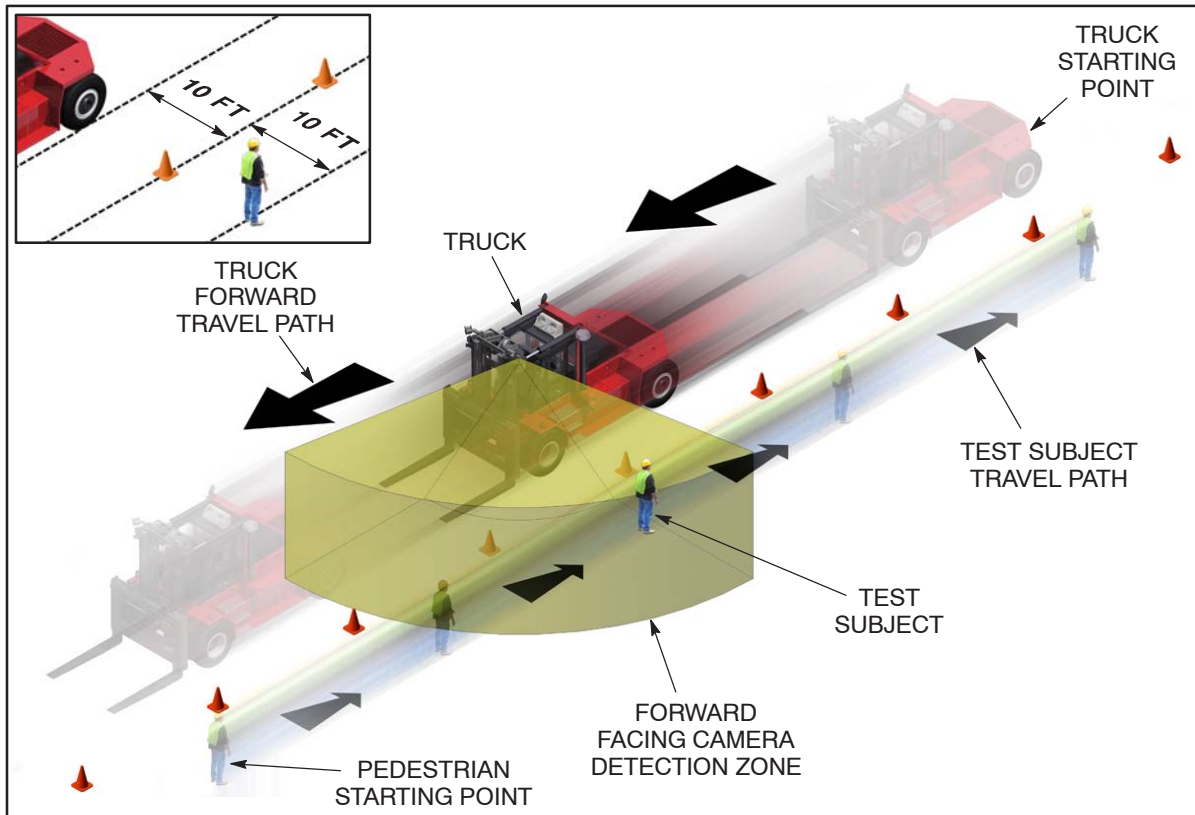

### Testing Rearward Facing Cameras

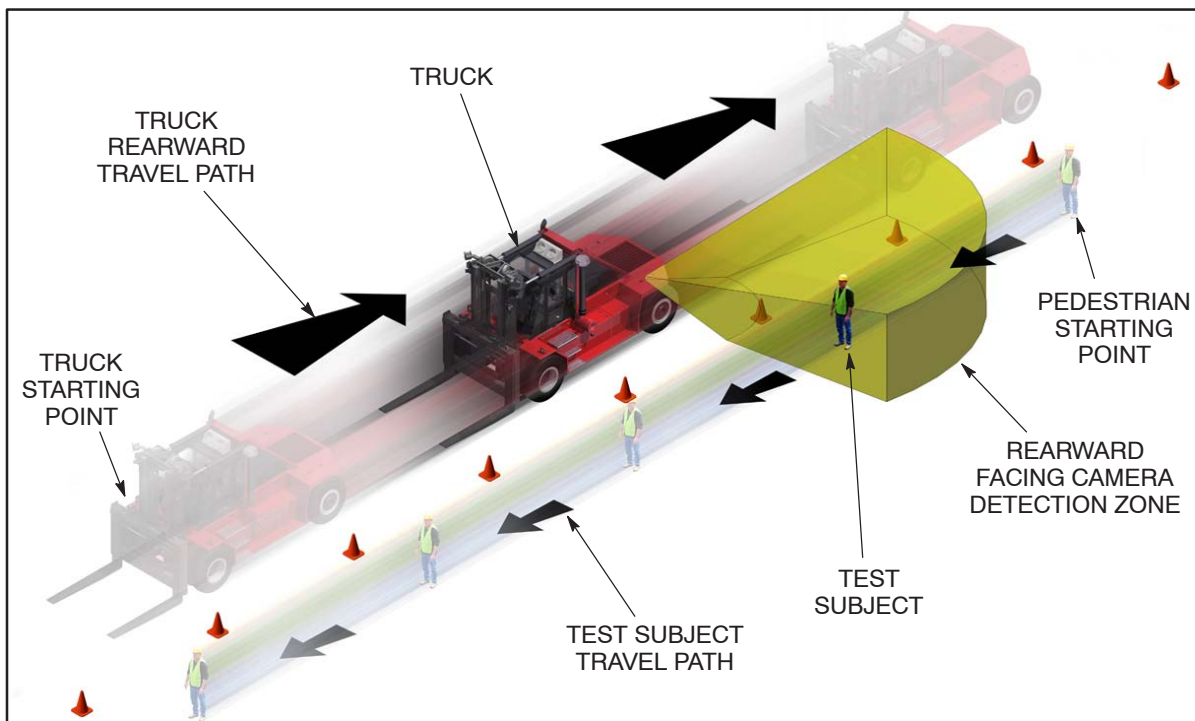



## Verification Travel Paths.

**⚠ WARNING:** Death or serious injury can occur from collisions. Follow all workplace safety procedures when setting up the verification travel paths. In addition, observe the following:

- Always use highly visible markers – such as travel cones – to establish a separation between the pedestrian travel path and the vehicle travel path.
- Ensure the pedestrian understands to always remain in the designated pedestrian travel path.
- Ensure the vehicle always remains in the designated vehicle travel path.
- Always keep communication with and maintain eye contact with the test subject.
- Use distinct signals – such as sounding the vehicle horn – to communicate the start and end of the test.
- Always look in the direction of and keep a clear view of the path of travel.

The verification procedure is performed by testing each camera as the pedestrian passes through its detection zone while the truck and the pedestrian are traveling in a straight line from opposite directions. See illustrations. For the test to be properly performed, a straight travel path 100 feet long and wide enough to allow the truck and pedestrian to travel in must be allowed. The travel paths of the truck and the pedestrian must be divided by a straight line of clear markers – such as travel cones – to ensure that the travel paths of the vehicle and the pedestrian never cross. The vehicle should travel in a straight line no more than approximately 10 feet from the markers while the pedestrian walks in a straight line no more than approximately 10 feet from the markers on the opposite side.

## Performance Verification Sequence.

The Performance Verification Procedure is used to test all cameras in the system. One camera cannot be verified without verifying the others. The previous verification data will be cleared as part of the Performance Verification Procedure. Once the camera verification data is cleared, the Vision Plus™ system will not return to normal operation until all cameras have been re-verified.

For each camera test, the truck and pedestrian must be positioned on opposite ends of the travel path and travel in a straight line, passing each other during the test. Each camera test will be complete when the selected camera detects the pedestrian and the camera's status reads "Pass". The Performance Verification Procedure will be complete when all camera tests read "Pass".

To perform the verification procedure:

1. Select "Reset Values" to clear all previous test data.

**NOTE:** When camera test data is cleared, the camera performance must be verified for all cameras and "Pass" must be shown on the Performance Verification Screen for all cameras before normal Vision Plus™ system operation can resume.

2. Position the truck and pedestrian at opposite ends of the previously established travel path. Before each camera test is performed, the pedestrian and vehicle must be separated by enough distance so that the pedestrian is not detected by the Vision Plus™ system. The pedestrian is being detected as long as there is an audible warning being given by the system control model or zone indicator display
3. Select "Performance Verification" to enable the verification mode. Ensure the camera Distance Check for the camera being tested reads "Fail" before each test.
4. Select the camera to be tested by selecting "Camera Select" until the desired camera is indicated. See Camera Location section of this manual for help in identifying the camera identification numbers.
5. The vehicle operator signals the beginning of the test by a previously established means such as sounding the horn and accelerates to full speed in first gear. At the same signal, the pedestrian begins walking in a straight line at a normal walking pace.
6. When the vehicle and pedestrian pass, the vehicle operator should signal the end of the test using the previously established means.
7. Repeat steps 3 through 6 for each camera until each camera's status reads "Pass".

**NOTE:** The vehicle and pedestrian must be oriented in each camera test so that the pedestrian will pass through the coverage area of the camera to be tested. It is possible that more than one camera can be tested using the same vehicle and pedestrian orientation.

8. Once all cameras have passed testing, select "Performance Verification" to exit the verification mode.
9. A system check must now be performed before continuing with normal system operation. Select "Perform System Check". The Vision Plus™ system is ready for use when the display returns to the Normal System Operation Screen.

In the event that operation of one or more cameras cannot be verified, discontinue use of the Vision Plus™ system immediately. Inform the proper maintenance personnel and contact your authorized Vision Plus™ dealer or installer for immediate service

**⚠ WARNING:** Death or serious injury can occur from using the Vision Plus™ system when it is not operating properly. Do not use the Vision Plus™ system if the Performance Verification Procedure cannot be completed.

---

## Diagnostics

**⚠ WARNING:** Death or serious injury may occur from using an improperly maintained Vision Plus™ system. Only authorized Vision Plus™ dealers and installers can perform maintenance on the Vision Plus™ system.

Maintenance and troubleshooting information will be displayed to the operator by way of the operator display module or the existing vehicle control system (TICS) depending upon installation.

### Zone Indicator Display

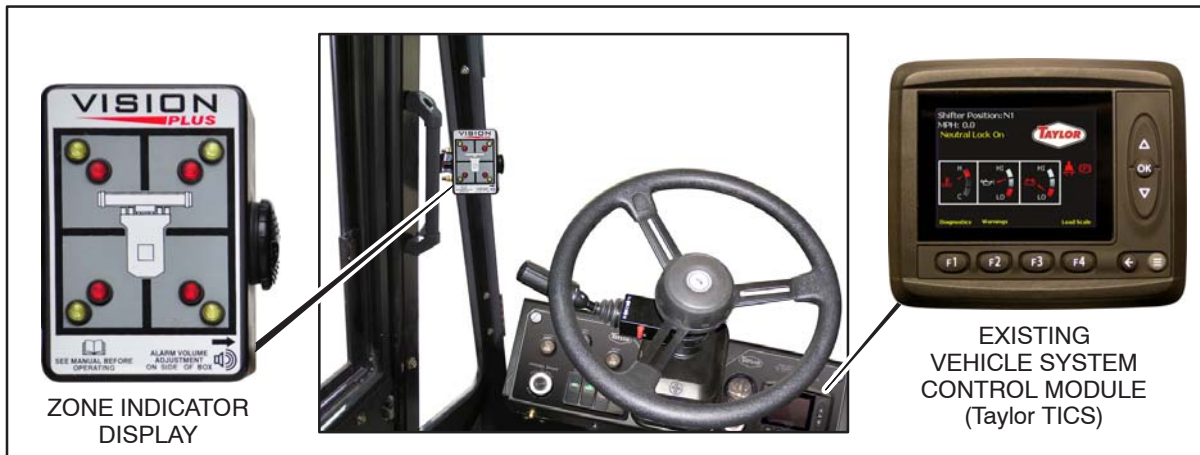

#### *Zone Indicator Display*



When there is a system malfunction or there is an issue with one of the cameras, an active warning will be automatically displayed on the TICS display module. If this condition occurs, the red indicator LEDs on the zone indicator display will flash. When all lights flash on the zone indicator display, the system has entered System Disabled Mode. Stop the vehicle, place the transmission control in Neutral, and select the Diagnostics option at the Main Screen of the TICS display module. At the Diagnostics screen, select the Vision Plus™ option. At the Vision Plus™ options screen, select the Errors option to view any active camera errors.

**⚠ WARNING:** Death or serious injury may occur from collisions. The Vision Plus™ system will not locate pedestrians when in system disabled mode. When all LEDs of the zone indicator display flash continuously, contact qualified maintenance personnel and discontinue use. Always look in the direction of and keep a clear view of the path of travel.

## Active Camera Errors

|  |  |
|--|--|
|  <p>The Active Warnings screen displays a list of ten warnings, each preceded by a red triangle icon. The warnings are: High Brake Temperature, High Brake Pressure, Low Brake Pressure, High Transmission Temperature, Reduce Speed, Shift Error, Low Hydraulic Oil Level, High Hydraulic Oil Temperature, Low Hydraulic Oil Temperature, and Check Vision Plus System - Press F4. Below the list is the text 'Active Warnings'. To the right of the list are two red warning icons: a triangle with an exclamation mark and a red octagon with the word 'STOP'. Below the screen are four function keys labeled F1, F2, F3, and F4, and two navigation buttons (back and menu).</p> <p>ACTIVE WARNINGS SCREEN</p> |  <p>The Errors screen displays the text 'PARTIALLY BLOCKED IMAGE FROM CAMERA 0' in white on a black background. Below this text is the instruction 'PRESS (F1) FOR MORE ERROR MESSAGES' in yellow. A white arrow points from this text to a physical device shown below. The device is a handheld unit with a screen displaying the same error message and a set of function keys (F1-F4) and navigation buttons.</p> <p>ERRORS SCREEN</p> |
|--|--|

## Operator Display Module

When there is a system malfunction or there is an internal issue with one of the cameras, a System Disabled Maintenance Screen will be automatically displayed on the operator display module. If this condition occurs, the red indicator light on the operator display module will flash continuously. Stop the vehicle, place the transmission control in Neutral, and press the F1 button at the System Disabled screen on the operator display module to view any active camera errors.

**⚠ WARNING:** Death or serious injury may occur from collisions. The Vision Plus™ system will not locate pedestrians with the System Disabled Screen active. When the System Disabled Screen appears, contact qualified maintenance personnel and discontinue use. Always look in the direction of and keep a clear view of the path of travel.

### Operator Display Module

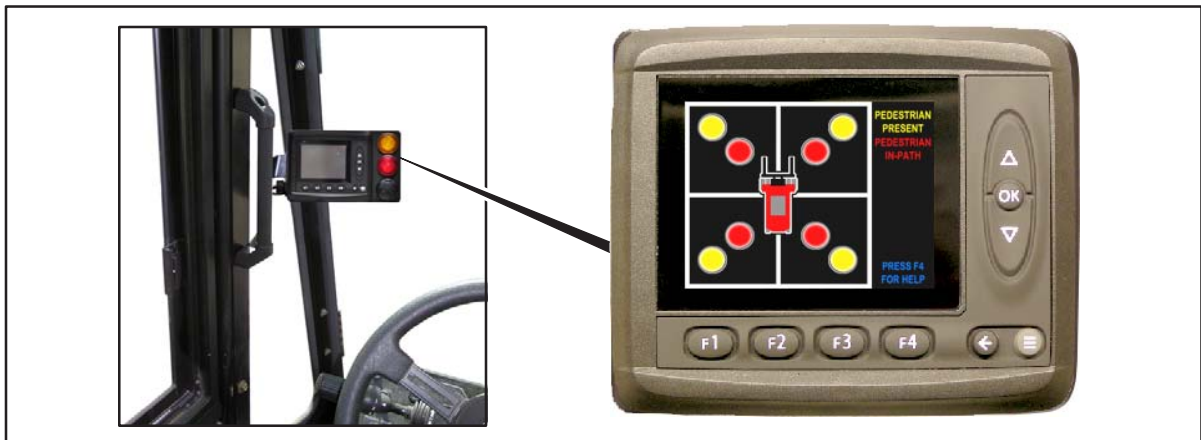

### System Disable Screen & Errors Screen

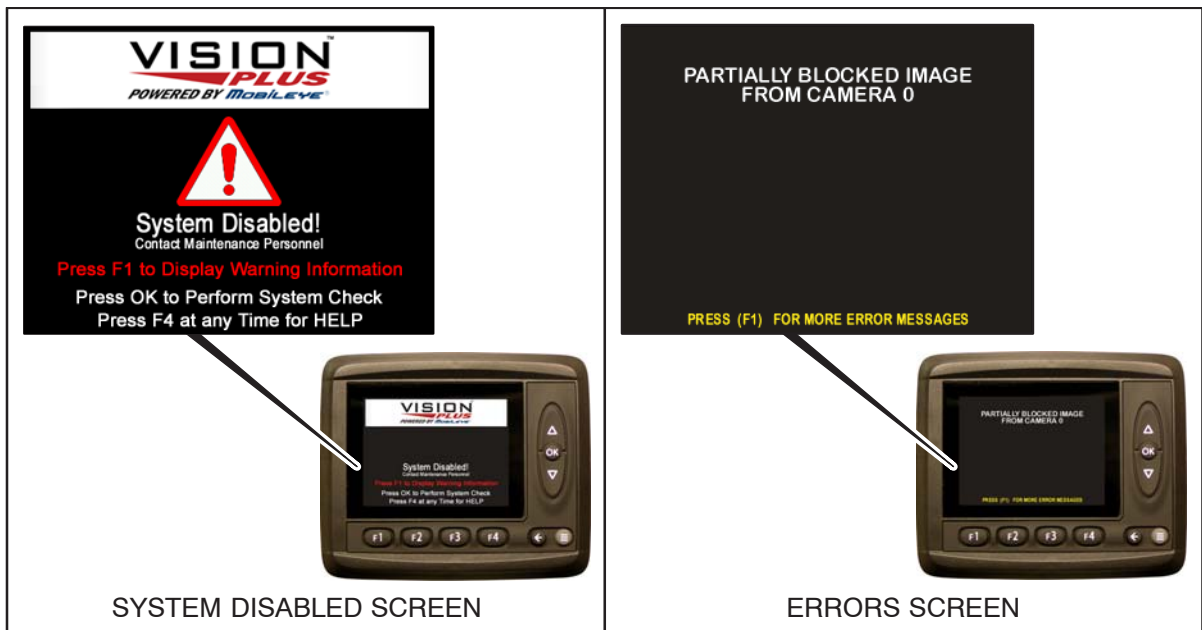

## Errors Screen

The Errors Screen displays the possible error(s) that can occur in the system. If necessary, press the F1 button to advance through multiple pages of errors. This information is useful to maintenance personnel in determining the possible source of the system error.

During operation of the Vision Plus™ system, it is possible that one or more cameras can become disabled due to electrical or internal failure. In these instances, the error will be "Check Camera". This error may require notification of your Vision Plus™ authorized dealer or installer.

If the error can be cleared by selecting "OK" to perform a system check, the system will resume normal operation. If the error does not clear, the red indicators will continue to flash until maintenance can be performed to clear the error. Do not rely on the system until the System Disabled Screen can be cleared.

**⚠ WARNING:** Death or serious injury may occur from collisions. The Vision Plus™ system will not locate pedestrians with the System Disabled Screen active. If the System Disabled Screen cannot be cleared, contact qualified maintenance personnel and discontinue use. Always look in the direction of and keep a clear view of the path of travel.

## Camera Locations

To aid in diagnosis of problems indicated by errors located on the Vision Plus™ Maintenance Information Screen, each camera is identified by a unique number. Part of this number is a position identification which is unique to the installation. The following illustration shows one example of the camera identification number and the mounting sequence.

**NOTE:** The Vision Plus™ system cameras can be configured in many ways. The following illustrations may not reflect the particular installation on this equipment but can be used as a general procedure to identify the cameras.

The camera's configuration in the Vision Plus™ system starts with Camera No. 0 located typically at the rear of the vehicle with all other cameras being sequentially numbered in a counterclockwise order. Camera No. 0 will be labeled to help in its identification. Refer to the separate System Configuration Sheet for specific information concerning camera locations on your vehicle.

*Camera Locations (8 Camera Configuration Example)*

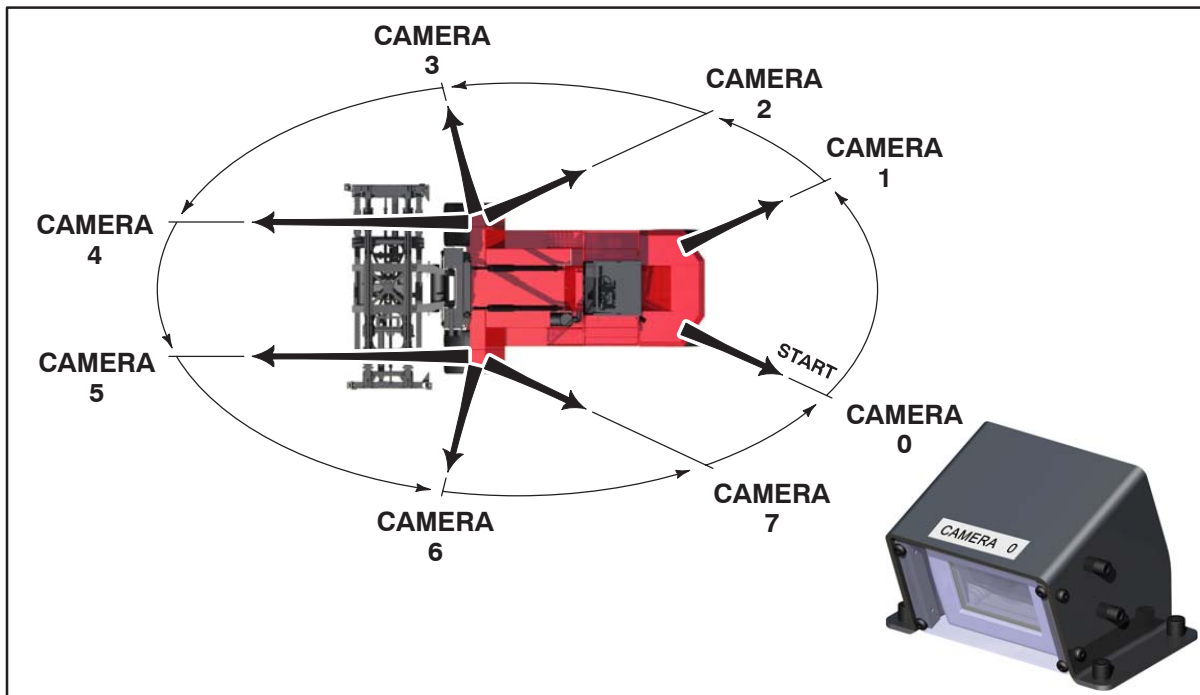

---

## Options

**⚠ WARNING:** Death or serious injury may occur from improper operation of the vehicle. Do not attempt to make adjustments or operate the function of the Vision Plus™ display while the vehicle is in operation. Bring the vehicle to a complete stop and set the parking brake before operating the Vision Plus™ display.

Information about help, errors, counters, and other information can be accessed at the Vision Plus™ Options screen. The Vision Plus™ Options screen can be accessed through the operator display module or the existing vehicle system control module depending on installation type.

To access the Options screen on systems equipped with the operator display module, bring the truck to a complete stop, set the parking brake, place the transmission control in neutral and press the F4 button at the Main Display screen.

To access the Options screen on the existing system control module (Zone Indicator Display Vision Plus™ system), bring the truck to a complete stop, set the parking brake, place the transmission control in neutral, press the F1 button at the Main Display Screen. At the Diagnostics Screen, press the Down arrow  and then press the F4 button.

### Options Screen



## Help

**⚠ WARNING:** Death or serious injury can occur from improper operation of the Vision Plus™ system. Always read and understand all information provided in this user guide before using the Vision Plus™ system.

Detailed operation, safety, and maintenance information is found in this guide and must be read and understood before operating a machine equipped with the Vision Plus™ system. For convenience some general guidelines may be accessed through the system help screens.



Illustrations

**WARNING!**  
Death or serious injury may occur from improper training. Read, understand and follow all operating rules found in the Vision Plus Operator's Manual.

ALWAYS look in the direction of and keep a clear view of the path of travel.

Press F4 for Next Page

Page 1

**What the Vision Plus™ System Does**  
Provides an audible warning and a yellow light when a pedestrian is in the coverage area

45 ft Max

“Beep!”

Yellow Light

Press F4 for Next Page

Page 2

**What the Vision Plus™ System Does**  
Provides an audible warning and a red light if the pedestrian and truck paths might cross

“Beep Beep Beep!”

Flashing Red Light

Press F4 for Next Page

Page 3

**What the Vision Plus™ System Does**  
When a detection is made, a visual warning is provided on the screen. The zone in which the pedestrian is located is illuminated.

OR

Press F4 for Next Page

Page 4

The system cannot see through obstacles

Area blocked by building

Press F4 for Next Page

Page 5

**SYSTEM PERFORMANCE MAY BE AFFECTED BY SEVERE WEATHER CONDITIONS**

**SYSTEM PERFORMANCE MAY BE AFFECTED BY POOR LIGHTING CONDITIONS**

Page 6

## Illustrations (continued)

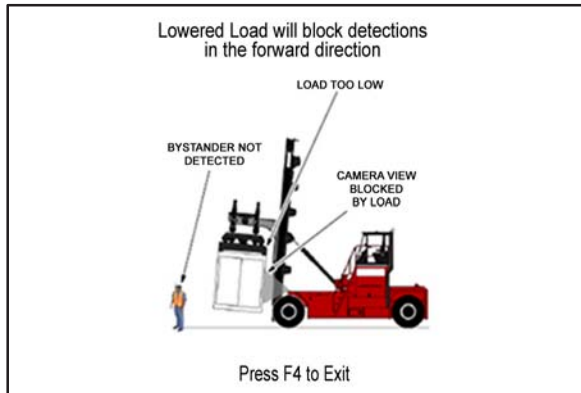

Page 7

## Errors

When an internal fault occurs with the Vision Plus™ system or one of its components during normal system operation, the operator will be notified with a System Disabled Screen or an active warning depending on installation type (see **Diagnostics** on page 19). At any other time, error information can be obtained through the Errors page of the Vision Plus™ Options screen.

## Counters

The Counters screen displays zone active count and in-path count information. The zone active counter counts the number of occurrences that a pedestrian present warning is activated. The in-path counter counts the number of occurrences that a pedestrian in-path warning is activated. The zone active count can be reset to zero by pressing the F1 button while the in-path count can be reset to zero by pressing the F3 button. The cumulative counts cannot be reset.

**NOTE:** It is possible that the system may provide more than one warning for a single pedestrian depending on the situation and the duration that the pedestrian is detected by the system. Therefore, actual number of pedestrians detected by the system may be less than the number shown on the counters screen.

## Counters Screen

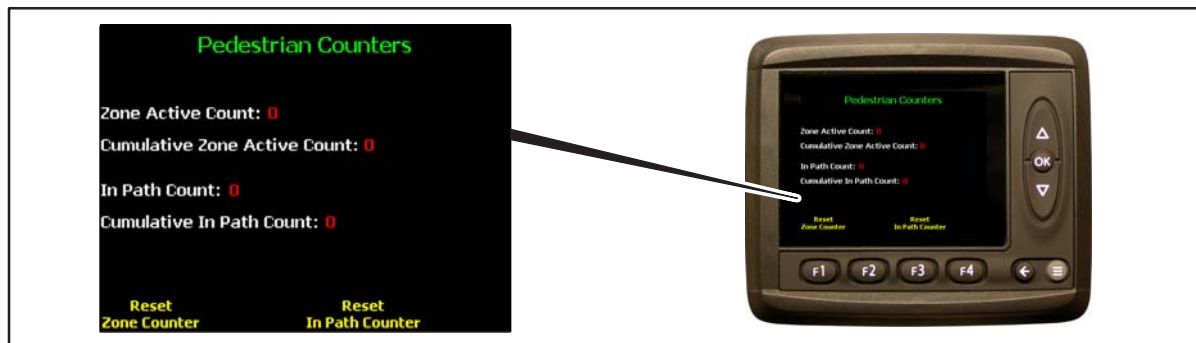

# Instructor's Guide for **VISION PLUS**<sup>TM</sup>

POWERED BY **MOBILEYE**

An Appendix of the Vision Plus Operator's Guide (OG-182)

## Before You Operate

### **Be Informed** (page 1, 2)

This document is not a replacement for the Vision Plus Operating Instructions, OG-182.

Read and understand all of the instructions included in the Vision Plus Operating Instructions, OG-182 before operating the Vision Plus<sup>TM</sup> system.

**▲ WARNING**: Death or serious injury may occur from improper operation.

- Always follow equipment manufacturer's operation instructions and safety information.
- Read and understand all of the instructions included in the Vision Plus Operating Instructions, OG-182 before operating the Vision Plus<sup>TM</sup> system.

### **Daily Checks (Prior To Operation)** (page 15)

The Vision Plus<sup>TM</sup> system performance can be affected by damage to the cameras, camera mounts, the vehicle, or components being misaligned or misadjusted. Always perform a daily visual check to ensure the cameras are not damaged or misaligned prior to equipment operation.

- The system can be rendered inoperable if the camera enclosure glass is not cleared of debris, grease, dirt, etc., or if scratching is excessive.
- Always ensure the system passes the startup test before continuing with use of the system.

### *Normal System Operation Screen* (page 8)

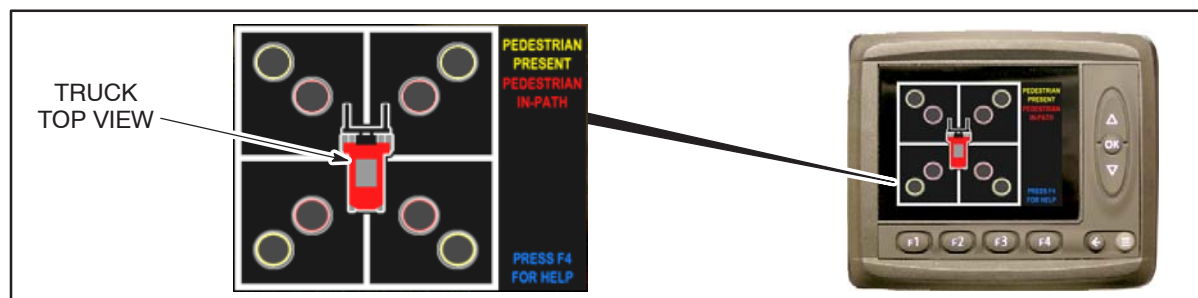

- Do not rely on the system if a system disabled warning or active warning cannot be cleared. Notify the appropriate maintenance technician.

### *System Disabled Screen* (page 29)

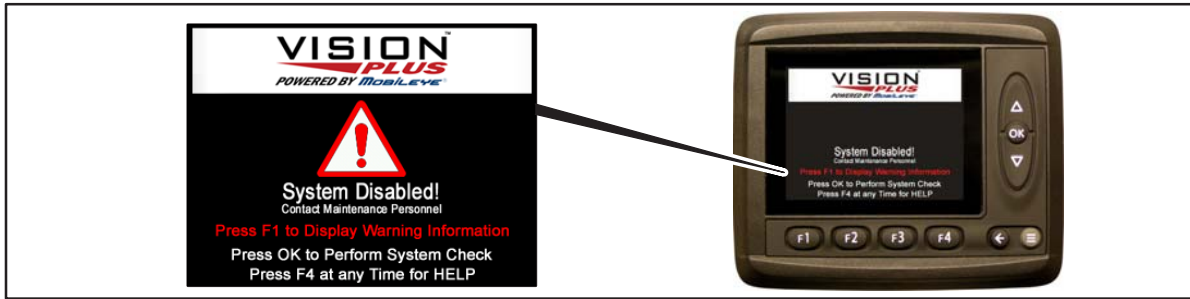

---

## During Operation

### **Use Direct Vision** (page 1, 2)

Always use direct vision in conjunction with the Vision Plus™ system. No device or alarm is perfect. Never depend on a safety device or alarm to clear the area of pedestrians. Be vigilant and always clear the path of travel with direct vision.

### **System Warning** (page 1–2, 9)

When the audible and/or visual warning information is provided, slow down if necessary, identify the area around the vehicle where the pedestrian has been detected, and immediately clear that area with direct vision.

### **Stopping Distance** (page 1, 2)

Understand that the normal detection range of the system is approximately 45 feet. Traveling at high speeds requires increased awareness because the time and distance required to stop the vehicle increase. There may be specific conditions, such as operating the vehicle loaded at high speeds where the distance required to stop the vehicle can be greater than the maximum detection range. Always keep a clear view of the path of travel and be aware of the distance required to bring the vehicle to a stop in the event of a detection.

### **Stop Before Adjusting** (page 1, 2)

Do not attempt to make adjustments or operate the functions of the Vision Plus™ display while the vehicle is in operation. Bring the vehicle to a complete stop and set the parking brake before operating the functions of the Vision Plus™ display.

---

## System Operation

### **Warning Types** (page 9)

The Vision Plus™ system has the capability of locating and tracking the detected pedestrian(s). Additionally, the Vision Plus™ system has the capability of tracking the movement of the equipment. Using these capabilities, the Vision Plus™ system can determine whether or not the paths of the equipment and pedestrian(s) could cross. These two possibilities (paths do not cross and paths may cross) enable the system to provide two distinct warning types to the operator.

## 1. Pedestrian Present. Paths will not cross.

A pedestrian has been located in one or more of the coverage area zones. Either the machine is not moving or the paths of the machine and pedestrians do not cross. In this case, the operator display will illuminate the yellow indicator in which the pedestrian(s) has been located. Additionally, an audible alarm will sound at approximately one "beep" every two seconds and the yellow "Caution" light will illuminate.

## 2. Pedestrian In-path. Paths will cross.

Pedestrian(s) within the coverage area may be moving in a direction that could cross the path of the vehicle or may be standing in the path of the moving vehicle. In the event that the potential paths of the vehicle and a pedestrian cross, or a pedestrian is standing in the path of the moving vehicle, the system will flash the red indicator on the zone in which the pedestrian is located. Additionally, an audible alarm will sound at approximately two "beeps" per second and the red "Warning" light will flash.

Detections are provided based upon a detailed warning scheme which depends on vehicle direction and speed. The operator must understand this warning scheme prior to operation. Refer to Directional Coverage Areas located in the front of the operator's guide.

### **Detectability** (page 16–21)

The Vision Plus™ system is a **line-of-sight system**. This means that only pedestrians within the direct view of the cameras can be detected. Simply put, each camera in the Vision Plus™ system acts as an extra set of eyes viewing the area around the equipment from the positions at which the cameras are mounted. If the view from the camera position to a pedestrian is blocked or partially blocked, more than likely, the pedestrian cannot be detected or "seen" by the camera or the system. If you could not see a pedestrian with your own eyes from the position that the camera is mounted, more than likely, the camera cannot see the pedestrian either and a warning will not be given.

#### **The Vision Plus™ system is a direct line-of-sight system.**

- The system can only locate pedestrians who are upright and walking or standing.
- The system can only locate pedestrians who can be "seen" by the cameras.
- Ensure areas behind loads or other obstructions are clear before operating.
- Attachments and loads which are lowered in front of the forward cameras will block the detection capability of those cameras. Any obstruction positioned in front of any camera will block the detection by that camera.
- Ensure both work area lighting and vehicle lighting are adequate. System performance will be reduced in poor lighting conditions.

### **Missed Detections** (page 17, 18)

There are specific conditions which can occur during machine operations which could cause the Vision Plus™ system to miss detecting a pedestrian. It is very important the operator understand these conditions and use the system accordingly.

The Vision Plus™ system will only detect pedestrians. Warning information will not be given for any obstacle other than pedestrians. Always keep a clear view of the path of travel.

The system may be adversely affected by severe weather conditions, differing lighting conditions, dark shadows, or other conditions that may obstruct the view of pedestrians. REMEMBER – the system can only detect pedestrians that can be "seen" by the cameras.

**Obstructions:** (page 18)

The system cannot "see" through obstructions such as containers, barriers or vehicles. For example, the necessity of the lift truck to pick and place loads in front of the vehicle creates a situation where the load will, at times, obstruct the forward cameras. Additionally, objects between pedestrians and the truck can obstruct the full view of the pedestrian. These specific instances where obstructions block the detections of the cameras require increased awareness by the operator to ensure – as in all situations – that the area has been cleared by direct vision before and during the times the equipment is operated in that area. See the following illustrations:

*Load Obstructions*

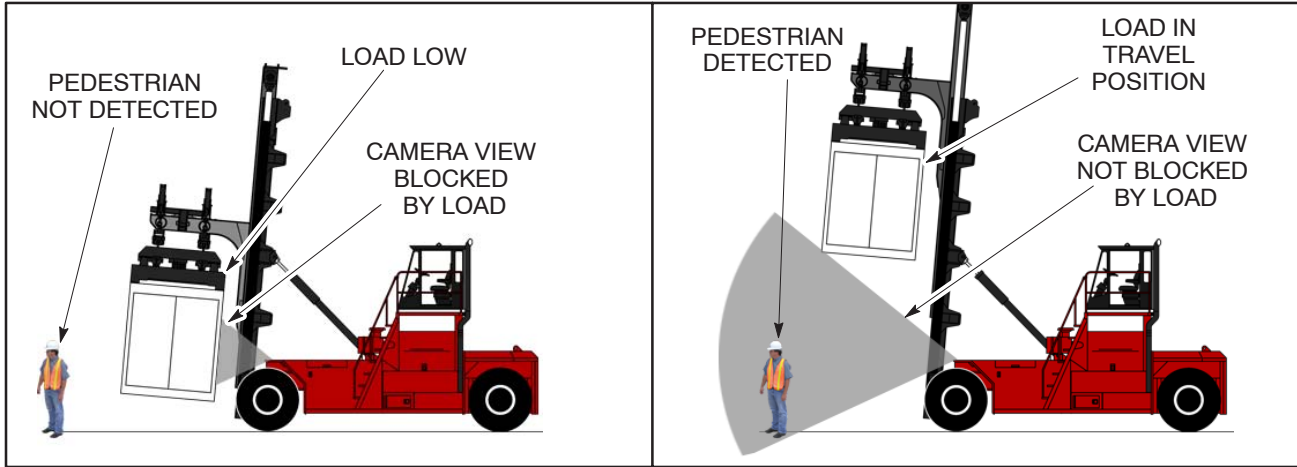

*Obstructions*

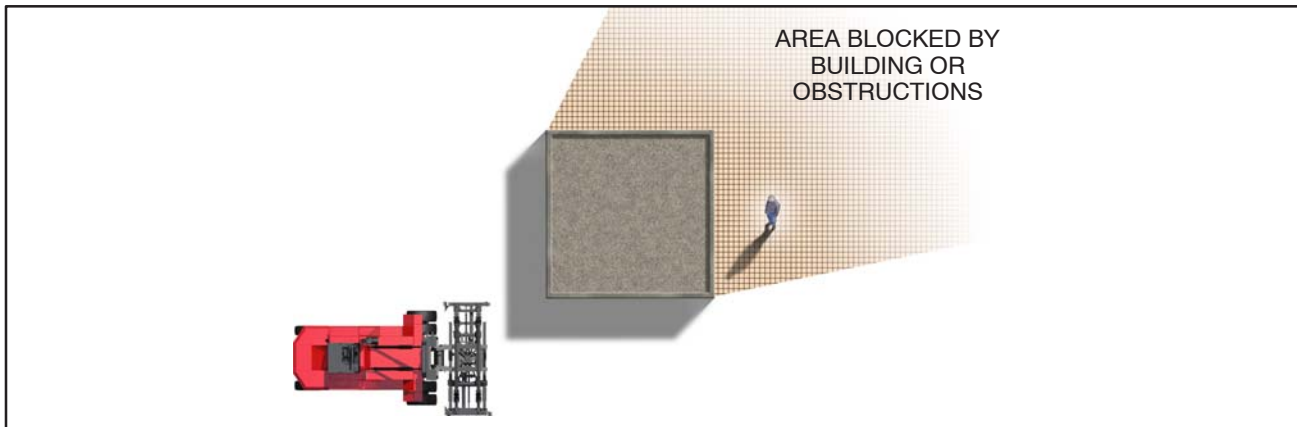

**Body Position:** (page 19)

The Vision Plus™ system relies on images and shapes to determine if a pedestrian is in the coverage area. Under normal circumstances, the Vision Plus\_ system only detects pedestrians who are upright and standing or walking. There may be instances when a pedestrian is in a body position which will not allow the system to recognize them as a pedestrian. Some examples of this are kneeling, lying down, or leaning against an object. In these instances, the pedestrian may go undetected. See the following illustrations.

*Body positions which may result in missed positions*

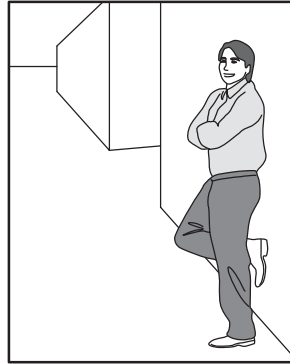

**Environment Clutter:** (page 20)

The Vision Plus™ system is designed to be used in almost all environments. Although, there can be specific conditions where the pedestrian can “blend” into the background. This can be caused by high amounts of clutter in the environment or by pedestrians wearing unusually patterned clothing. Remember, if it is difficult to see a pedestrian with direct vision, more than likely, the system will have difficulty also.

**Extreme Weather Conditions:** (page 19)

Detection may also be affected by severe weather conditions which could include heavy rain, dense fog, snow, ice, etc. As an example, if weather conditions are severe enough to hinder the operator’s direct vision, similarly, Vision Plus™ detection performance will be hindered.

*Blockage Due To Weather*



**Lighting Conditions:** (page 20)

Detection may be affected by varying lighting conditions. An area too dark to see pedestrians with direct vision will also be too dark to detect pedestrians with the Vision Plus™ system. Always ensure work area lighting and worklights installed on the equipment are adequate to illuminate the coverage area during all operations.

*Lighting Conditions*



## **Late Detections Or Reduced Performance** (page 20)

There are specific conditions which can occur during machine operations which could cause the Vision Plus™ system to detect pedestrians at a reduced range. It is very important the operator understand these conditions and use the system accordingly.

### **Shadows:** (page 20)

Under most operating conditions, pedestrians passing through shadows will not cause a decrease in performance. Although, there can be extremely abrupt changes from very light, bright areas to very distinct dark shadows which can cause a decrease in system performance. Slow down and use extra caution in these areas.

### **Damage:** (page 4)

The Vision Plus™ system performance can be affected by damage to the cameras, camera mounts, the vehicle, or components being misaligned or misadjusted. Always perform a daily visual check to ensure the cameras are not damaged or misaligned.

**⚠ WARNING:** While the Vision Plus™ system can detect on its own when a camera is malfunctioning, the system cannot detect on its own a misaligned camera.

Familiarize yourself with the proper alignment of the cameras so that it will be more likely that a problem can be noticed during the pre-operational check. Loose bolts, damaged brackets, damaged mounting surfaces, and scratched paint could be indicators that a camera should be checked for alignment problems.

### *Mis-alignment Due To Parts Damage*

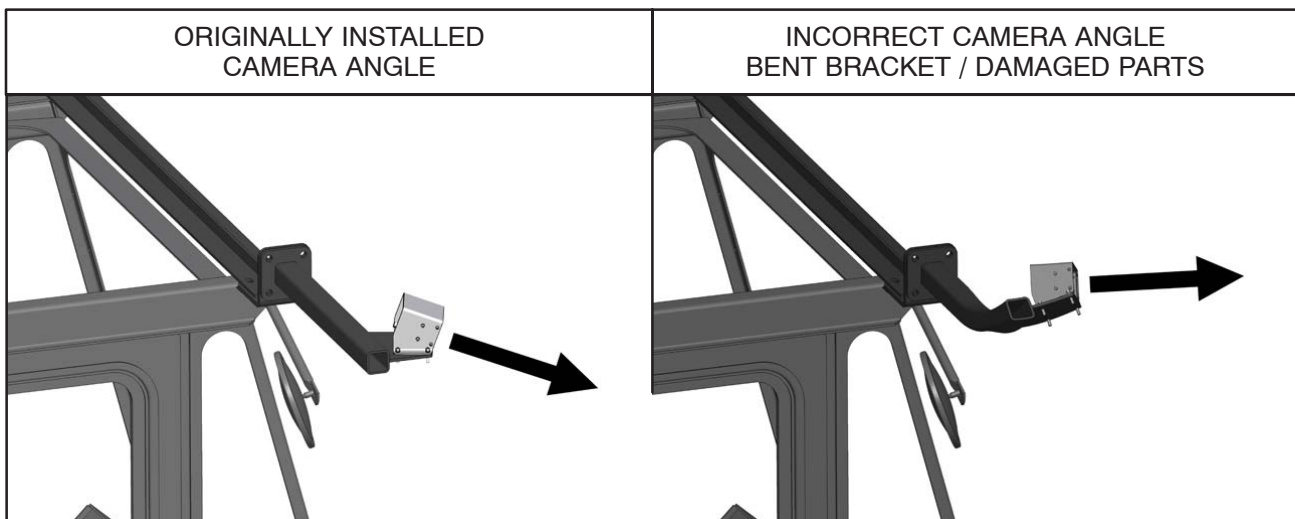

### **False Detections** (page 21)

Although the Vision Plus™ system drastically reduces the number of non-meaningful alarms to the operator, there are specific conditions when the system can return a false alarm. Objects in the environment which have similar shapes as pedestrians can cause the system to provide an alarm. See illustrations below:



*Objects which may result in false detections*

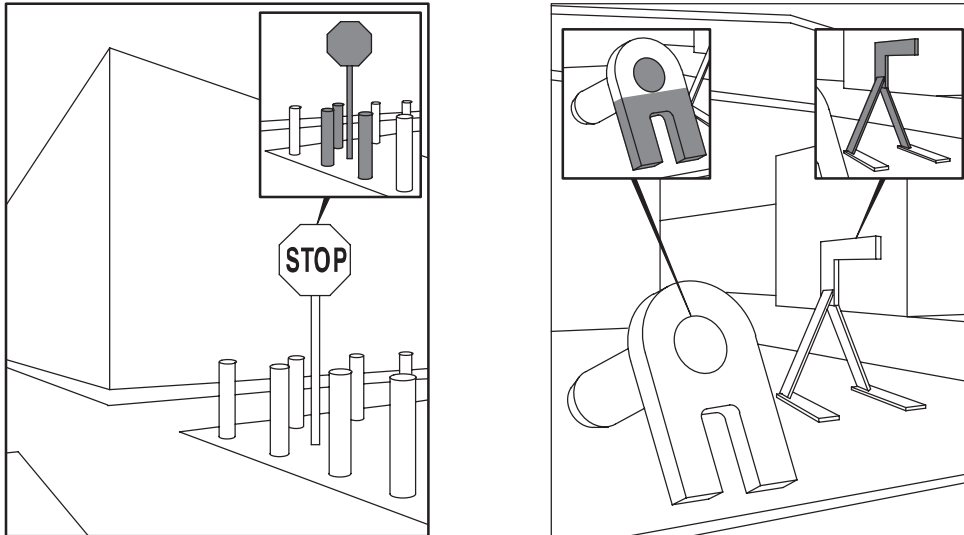

*No alarm should be ignored.* When an alarm is given, the operator must clear the area with direct vision. These types of false detections can be minimized by identifying objects in the environment which repeatedly return false detections and modifying their appearances.

## LIMITED WARRANTY

Vision Plus™, powered by Mobileye is sold and warranted by Vision Plus™, a division of Taylor Machine Works, Inc. to be free from defects in material and workmanship, under normal use and service, when operated under the guidelines set forth in the Operator's Guide, and provided the system has been installed by a certified Vision Plus™ dealer or installer. This warranty is limited to repair or replacement, (as Vision Plus™ may elect, and at an establishment authorized by Vision Plus™) of such parts as shall appear to Vision Plus™ upon inspection to have been defective in material or workmanship.

This warranty period shall begin on the delivery date of the product to the Purchaser and end twelve (12) months thereafter. During this period, Vision Plus™ will provide genuine Vision Plus™ parts to replace or repair any part furnished by Vision Plus™ and found to be defective in material and workmanship. Only genuine Vision Plus™ parts will be used during the warranty period. Warranty repair or replacement must be performed by a certified Vision Plus™ dealer or installer. Repairs, replacement, installation, or modification of any part of the Vision Plus™ system by non-trained and certified personnel shall render the entire Vision Plus™ system and all its components warranty void.

### THE FOLLOWING ITEMS ARE NOT COVERED BY THIS WARRANTY:

1. Normal maintenance services and parts or supplies used therein including, without limitation, replacement of fuses, bulbs, glass; shop supplies such as rags, oil dry, hand soaps, degreasers, cleaning solutions, etc.; and adjustments which are a part of the required installation procedures in accordance to the Certified Dealer Installation Checklist and Warranty Validation.
2. Normal deterioration of appearance due to use and exposure; or conditions resulting from misuse, negligence, or accident.
3. Any parts or accessories installed on the product which were not manufactured or installed by Vision Plus™ whether or not such parts or accessories were selected, recommended or installed by Vision Plus™.
4. Loss of time, inconvenience, loss of equipment use, other consequential damages or other matters not specifically included.

All International warranty parts shipments are F.O.B. point of debarkation, duties, tariffs, or local taxes excluded.

This warranty is expressly in lieu of any other warranties, expressed or implied, including any warranty of merchantability or fitness for a particular purpose.

Replacement parts are warranted for ninety (90) days to be free from defects in material or workmanship.

Vision Plus™ does not authorize any person to create (for Vision Plus™) any other obligation or liability in connection with Vision Plus™ products.

**VISION PLUS™, powered by Mobileye**

A division of Taylor Machine Works, Inc.

650 North Church Avenue

Louisville, MS 39339

(662) 773-3421 / Fax 662-773-9146



